

AUS Repository

Intelligent Multi-Sensor Process Condition Monitoring

Item Type	Thesis
Authors	Hammad, Firas
Download date	2026-03-07 06:25:07
Link to Item	http://hdl.handle.net/11073/122

INTELLIGENT MULTI-SENSOR PROCESS
CONDITION MONITORING

A THESIS IN MECHATRONICS

Presented to the faculty of the American University of Sharjah
College of Engineering
in partial fulfillment of
the requirements for the degree

MASTER OF SCIENCE

by
Firas Hammad
B.S. 2005

Sharjah, UAE
December 2007

© 2007

FIRAS HAMMAD

ALL RIGHTS RESERVED

We approve the thesis of Firas Fahed Hammad

Signature

Date of signature

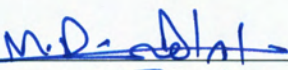

Dec 11 2007

Dr. Ibrahim Deiab
Assistant Professor of Mechanical Engineering
Thesis Co-Advisor

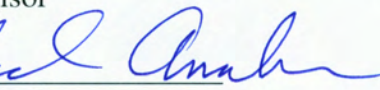

Dec. 11, 2007

Dr. Khaled Assaleh
Associate Professor of Electrical Engineering
Thesis Co-Advisor



Dec. 11, 2007

Dr. Hany El Kadi
Associate Professor of Mechanical Engineering
Graduate Committee



Dec 11 2007

Dr. Khalifa Harib
Assistant Professor of Mechanical Engineering
External examiner, UAE University
Graduate Committee

Dec. 12, 2007

Dr. Rached Dhaouadi
Coordinator, Mechatronics Graduate program

12/12/2007

Professor Jamal A. Abdalla
Professor
Director, Graduate programs

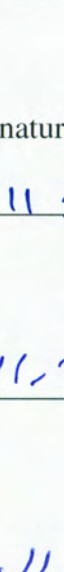

12/12/07

Professor Yousef Al-Assaf
Professor
Dean, College of Engineering



12/12/07

Mr. Kevin Mitchell
Director, Graduate and Undergraduate programs

AN ABSTRACT IN AN AMERICAN
UNIVERSITY OF SHARJAH THESIS:

INTELLIGENT MULTI-SENSOR PROCESS CONDITION
MONITORING

Firas Hammad, Candidate for the Master of Science

American University of Sharjah, 2005

ABSTRACT

Loss of production and machine breakdown are critical challenges facing modern machining. The main objective of this work is to develop an intelligent multi-sensor process condition monitoring that is able to predict the wear propagation in the cutting tool using information obtained from the analysis of cutting force and acoustic emission (AE) signals generated during turning of steel. The time domain for cutting forces and AE signals are processed for relevant features about fresh and worn tools. Principal component analysis (PCA) is used to eliminate redundant and irrelevant features. The most relevant features are used as inputs for the two classifier used in this investigation, namely, back propagation neural network (BPNN) and polynomial classifier (PC). The classifiers parameters are optimized to achieve faster computations and better predictions. To improve accuracy, leave-one-out (LOO) method is used to train both classifiers. LOO uses all the data samples for training the system. Classifiers training is modeled by correlating the extracted features with the actual measured tool wear. Comparing to BPNN, PC shows a dramatic reduction in training and prediction time. The results show the effectiveness of PCA in selecting feature that retains as much as possible of the

variation in the original data. Such a system is of vital importance to the automation of manufacturing facilities. Also the use of features enhances the accuracy of both method in comparison to the use of raw data.

CONTENTS

ABSTRACT.....	iii
LIST OF FIGURES	vii
LIST OF TABLES	viii
ACKNOWLEDGEMENTS	ix
CHAPTER 1: INTRODUCTION.....	1
1.1 Preamble	1
1.2 Scope of work	1
1.3 Thesis layout	2
CHAPTER 2: LITERATURE REVIEW	3
2.1 Introduction.....	3
2.2 Tool wear	4
2.3 Acoustic emission	7
2.4 Machine condition monitoring.....	8
2.5 Summary	14
CHAPTER 3: DATA COLLECTION AND EXPERIMENTAL WORK	15
3.1 Experimental setup.....	15
3.2 Experimental procedure	16
3.3 Signal pre-treatment.....	18
3.4 Summary	20
CHAPTER 4: MODELING AND SIMULATION OF TOOL WEAR USING ANN AND PC.....	21
4.1 Introduction.....	21
4.2 Feature extraction.....	21
4.2.1 Feature assessment criteria	23
4.3 Modeling strategy	25
4.3.1 Neural network.....	26
4.3.2 Polynomial classifier.....	29
4.3.3 Leave One Out	31
4.4 Summary	32
CHAPTER 5: RESULTS AND DISCUSSION.....	33

5.1 Introduction.....	33
5.2 Results from ANN and PC.....	40
5.2.1 Results from ANN model	40
5.2.2 Results from polynomial classifier model	49
5.3 Comparison between neural network and polynomial classifier	54
5.4 Summary	55
CHAPTER 6: CONCLUSION AND RECOMMENDATION FOR FUTURE WORK..	56
6.1 Conclusion	56
6.2 Recommendation for future work.....	57
VITA.....	64

LIST OF FIGURES

Figure 1: Cross-sectional view of the machining process	4
Figure 2: Worn cutting tool.....	5
Figure 3: Types of tool wear.....	6
Figure 4: Tool wear as a function of cutting time.....	6
Figure 5: Typical AE signal in turning	8
Figure 6: Experimental set up.....	16
Figure 7: Force signal pre-treatment.....	19
Figure 8: AE signals pre-treatment.....	20
Figure 9: Nonlinear model of a neuron.....	27
Figure 10: Architectural graph of MLP	28
Figure 11: Architectural graph of polynomial classifier.....	29
Figure 12: Force signals in the three axes.....	34
Figure 13: RMS and raw AE signals	35
Figure 14: AE data projected in PCA	36
Figure 15: Variation of AE features.....	37
Figure 16: Force data projected in PCA	38
Figure 17: Variation of AE features.....	39
Figure 18: Conventional NN for prediction tool wear.....	41
Figure 19: Prediction tool wear using least square	42
Figure 20: Measured and predicted tool wear through LOONN using S1 set.....	46
Figure 21: Measured and predicted tool wear through LOONN using S4 set.....	47
Figure 22: Measured and predicted tool wear through LOONN using S6 set.....	48
Figure 23: Measured and predicted tool wear through LOONN using S2 set.....	49
Figure 24: Measured and predicted tool wear through LOOPC using S6 set.....	51
Figure 25: Measured and predicted tool wear through LOOPC using S2 set.....	52
Figure 26: Measured and predicted tool wear through LOOPC using S1 set.....	53
Figure 27: Measured and predicted tool wear through LOOPC using S4 set.....	54

LIST OF TABLES

Table 1: Specification of workpiece	15
Table 2: Machining parameters	16
Table 3: Machining monitoring setup.....	17
Table 4: Total variability of AE features	38
Table 5: Feature list	43
Table 6: NN trial 1 ($v = 130$ m/min, $f = 0.15$ mm/rev).....	44
Table 7: NN trial 2 ($v = 170$ m/min, $f = 0.2$ mm/rev).....	44
Table 8: NN trial 3 ($v = 190$ m/min, $f = 0.15$ mm/rev).....	44
Table 9: PC trial 1 ($v = 130$ m/min, $f = 0.15$ mm/rev).....	50
Table 10: PC trial 2 ($v = 170$ m/min, $f = 0.2$ mm/rev).....	50
Table 11: PC trial 3 ($v = 190$ m/min, $f = 0.15$ mm/rev).....	50

ACKNOWLEDGEMENTS

I would like to take this opportunity to thank many people who helped to make this thesis possible. My deepest gratitude goes to my advisors, Dr. Ibrahim Deiab and Dr. Khaled Assaleh. Without their constant inspiration, guidance, encouragement and support, this thesis is nearly impossible. I am also grateful for their knowledgeable advice and valuable input for my thesis development. I would also like to express my sincere appreciation to many friends Eng. Mohammad Khanfar for his friendship and countless hours of help and support. Special thanks to Eng. Amal Khattab for her enormous and useful help. I am also grateful to the machinist Ricardo De Jesus for his help in the experimental part of this work . Finally, I am in debt, forever, to my parents for what they have done for me. This thesis could not have been successfully completed without their help and encouragement. Special thanks must also be given to other members of my family, sisters and brother.

CHAPTER 1: INTRODUCTION

1.1 Preamble

This master thesis investigates the use of multi-sensors in tool conditioning monitoring in turning process. This work studies the wear propagation in cutting tool during turning process. Knowing the tool status leads to systematic replacement and maintenance schedule. In addition, catastrophic failures are minimized, better product quality are achieved, and resources are efficiently used. This master thesis is part of ongoing studies on the tool condition monitoring. To be so, a new sensor and a novel classification method are used. Extensive experimental laboratory work is performed together with computer simulations to develop a model for the tool wear propagation. Results shows that tool wear prediction is successfully modeled.

1.2 Scope of work

The notion of machine/processes monitoring is associated with the automation of any process. In manufacturing, machine condition monitoring has been applied in many areas to monitor machine tool vibration, spindle life and tool wear. Many sensors such as vibration and force sensors have been used for fault detection. The scope of this work will be focused on indirect monitoring and detection of cutting tool wear progression while machining metals in turning operations. In order to produce various tool wear progression schemes, cutting conditions are varied using the experimental design of Tagushi. In this work, a new approach is proposed to overcome two main problems of existing approaches: namely high cost sensors on the one hand and computationally time consuming modeling techniques on the other hand. In addition to a dynamometer, a highly cost force sensor, and low cost acoustic emission sensor are used. Results from each sensor individually and combined are to be observed. To predict tool wear two artificial intelligence schemes are applied. First, a modified back-propagation neural network, using leave one out method, for better prediction accuracy has been

investigated. Second, polynomial classifier, which is a novel technique in pattern recognition with quicker convergence and better prediction accuracy, has been applied. To the best of the author knowledge and belief, no work has been published in this field by another person using the above-mentioned techniques. The key of success of pattern recognition models is the relevant feature extraction. This work analyzes the correlation between the output signal and the tool wear by the time domain analysis, statistical features, of the output signals.

1.3 Thesis layout

Chapter 2 provides a general background about tool wear in cutting tools and the nature of the acoustic emission generated during machining. It also presents a review of machine condition monitoring and the various type of intelligent systems that have been used in this field. Chapter 3 describes the methodological approach that is used and the experimental setup including specimen material, inserts, machine, and sensors. In chapter 4, the modeling approaches that are used to model tool wear are presented. Two discriminative models are described to predict tool wear and classify tool states, namely neural network and polynomial classifier. Feature extraction and feature evaluation is also presented. In chapter 5, signals acquired from sensors are analyzed. Features extraction and the way to evaluate them are presented. In addition, the two methods on a different dataset have been evaluated. The results from both models are compared. Finally, chapter 6 concludes the thesis and includes a brief outline of the major outcome results, with some recommendations for future work

CHAPTER 2: LITERATURE REVIEW

2.1 Introduction

With the increased global competition, demand for more environmentally benign manufacturing processes and increased production cost the manufacturing sector is vigorously working on enhancing the efficiency of manufacturing processes in terms of cost, quality and environmental impact. One concept that poses itself in this direction is automation and unmanned manufacturing facilities to reduce overhead cost and enhance product quality. Another fold to the solution is the use of newly engineered materials with high strength to weight ratio. Such materials would results in lighter products and more efficient engines with less harmful emissions to environment. The down side of the latter option is that such materials are difficult to cut materials in terms of their high tool wear rate.

In manufacturing, metal cutting is a daily on going process. Finishing cut is almost always used to achieve the design constraints on surface finish and to achieve the required design tolerances. These two criteria are significantly affected by the state of the cutting tool. Since cutting tool is at the heart of this process, its health status is crucial in industrial applications. Therefore, the need for automated manufacturing systems, that are able to up-date the user with accurate information about the process, has increased.

Business does not tolerate equipment failures, machine breakdowns, and material damage. This can occur due overusing the consumable parts: for instant cutting inserts. As a result, companies worldwide tend to use smart monitoring technologies, which can predict any catastrophic failure. At the same time, these companies insist on getting back value for money for their investment in tool condition monitoring (TCM) technologies. In this sense, more pressure will be for development of smart methods concerning such major economic concern. TCM can save human lives, as they can take adequate steps before any machine failure. All of this and more encourages the research community and the industrial sector to investigate and find out better ways to study this phenomenon.

2.2 Tool wear

In metal machining, excess material is removed from the starting work piece so that the remaining part has the final desired shape. This process is called material removal process. The most important member in this process is a sharp cutting tool that is used to mechanically remove material. In machining shear deformation of the work piece occurs for this removal process. Figure 1 illustrates machining process.

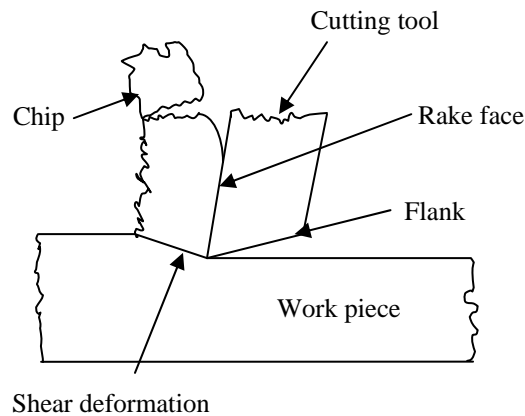

Figure 1: Cross-sectional view of the machining process

In this process, high forces and temperatures are generated. This creates a very harsh environment for the tool. In these extremely arduous conditions, three scenarios are possible for a tool failure

- a) The cutting force is too large and excessive, causing the tool to suddenly fracture.
- b) The cutting temperature is too high causing the tool material to soften and fail due the plastic deformation.
- c) Continuous removal process leads gradual wearing of the cutting edge. This causes a loss of the tool shape and a failure.

Of the three possible tool failure modes, part c is preferred because it ensures the longest possible usage of the tool. This is the optimum condition that ensures cost reduction, i.e. economical advantage.

From figure 1 two main locations can exhibit the tool wear highlighted in point c at the top rake face and the flank. This can classify the tool wear into a crater wear and flank wear [1]. The two locations are shown in figure 2. Crater wear is a concave section on the rake face of the tool. It occurs due the chip sliding against the surface. This type of wear can be measured either by its depth or its area. The second type, “flank wear” results from rubbing between the newly generated flank face and work piece surface. It is measured by the width of the wear band.

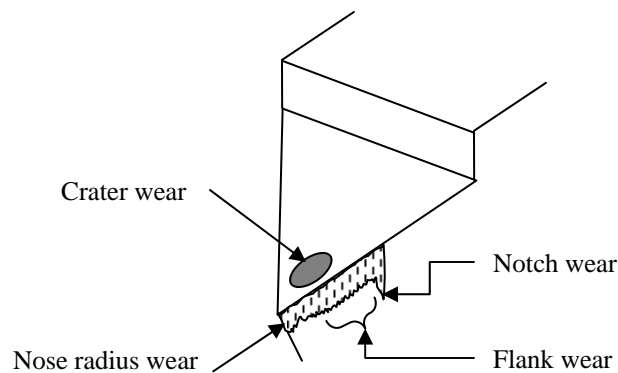

Figure 2: Worn cutting tool

Notch wear and nose radius wear are two types of flank wear. The former occurs because of variation in the hardening between the outer surface and the internal material from previous machining or other reasons. It is located on the original surface of the work piece. The nose radius wear occurs on the nose radius of the tool. Figure 3 summarizes the types of the tool wear.

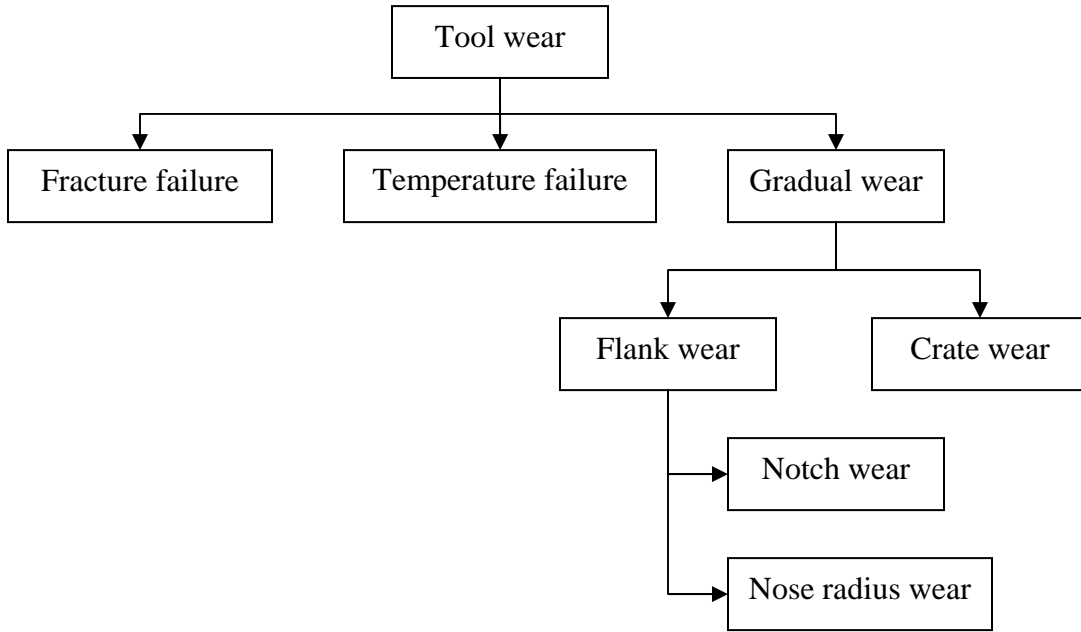

Figure 3: Types of tool wear

Tool wear with time can be divided into three regions. These regions can be identified in a wear growth curve. Figure 4 depicts flank wear. The first region is a break-in period, where a sharp tool wears rapidly. It is followed by steady state wear, in which the wear is uniform. The last region is the failure region, in which wear starts to accelerate, and temperature increases and tool eventually fails.

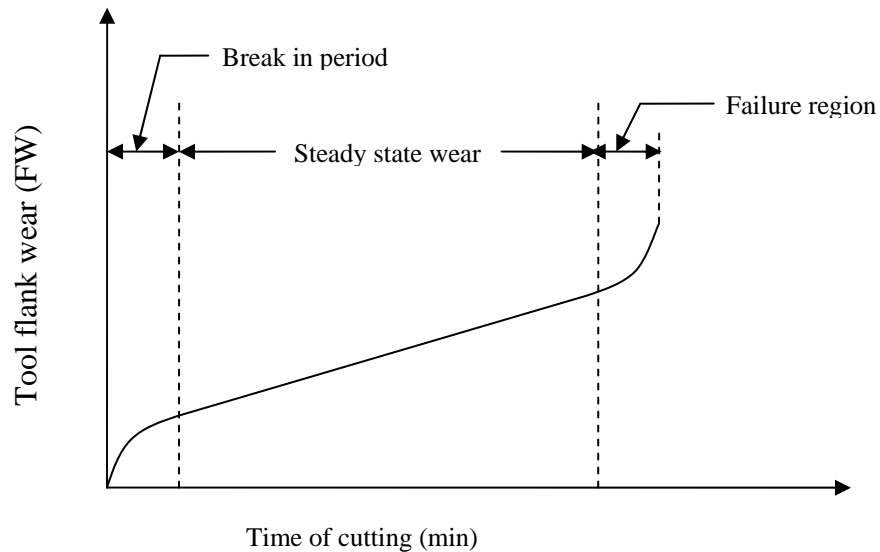

Figure 4: Tool wear as a function of cutting time

2.3 Acoustic emission

Acoustic emission is a transient elastic wave that is generated from rapid and spontaneous release of energy in material undergoing permanent deformation [2]. This wave is considered as a stress wave, which propagates through the material at approximately the speed of sound. The stress wave can be attenuated, reflected, and/or distorted. A piezoelectric transducer is used to detect acoustic emission. It can be directly mounted on the specimen or indirectly, since the stress wave can propagate through the mechanical structures. AE has been used to detect tool wear in turning machining. Continuous and transient signals are the two types of AE signals acquired in turning. The former is a low amplitude high frequency associated with plastic deformation during the cutting process in the workpiece, plastic deformation in the chip, frictional contact between the tool flank face and the workpiece resulting in flank wear, and frictional contact between the tool rank and the chip resulting in crater wear. The transient or burst signal is a high amplitude, low frequency associated with collision between chip and tool, chip breakage, and tool fracture. Therefore, the continuous part of AE signal is used to monitor tool wear. The major advantage of using AE signals is that the frequency range of the AE signal is much higher than that of the machine vibration and environmental noise.

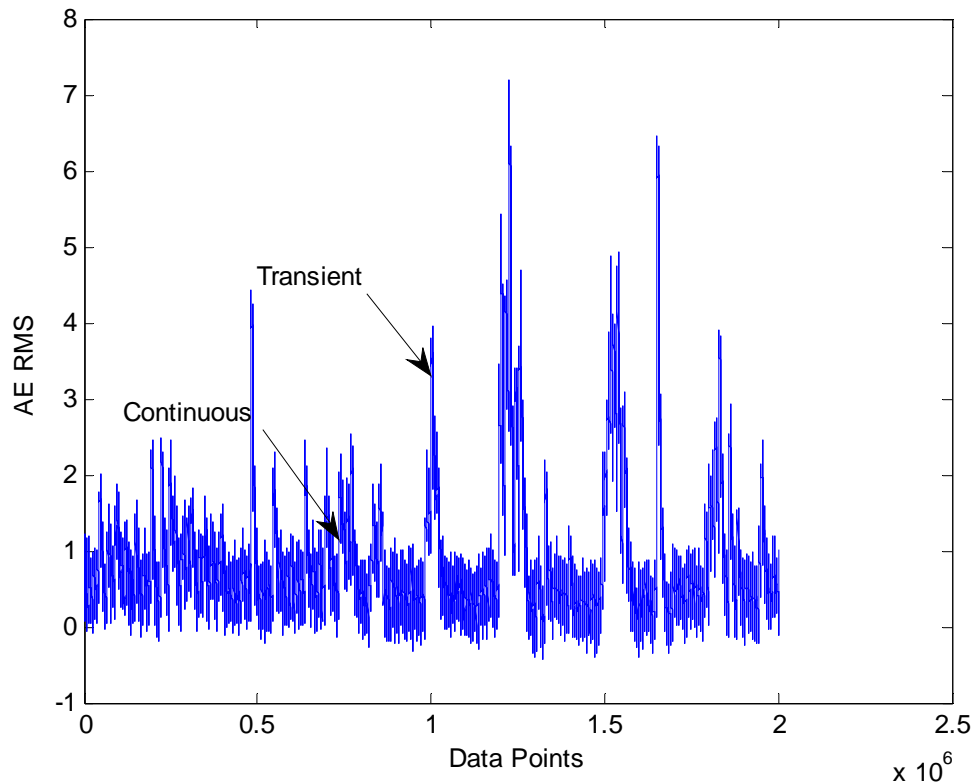

Figure 5: Typical AE signal in turning

2.4 Machine condition monitoring

In tool condition monitoring (TCM), the system gathers information about the overall process. It is done through cues captured by different types of signals. Each signal is generated from separate source, namely a sensor. These signals represent various operation parameters such as cutting speed, energy consumption, sound and others. Considerable research used acoustic emission, vibration, cutting force, and temperature sensors. Some of them are used alone or combined, sensor fusion [3,4].

After having these signals as inputs to TCM system, an intelligent system is needed to interpret them. This system will make a conclusion about the status of the process, as output. Different kind of decision making techniques have been used to predict tool wear. Artificial Neural networks (ANNs) are a typical example of an intelligent system. With ANNs, it is possible to create a system that is able to learn and adapt to any change in the operation parameters. It can be stated that multi-layer

perceptrons of the back propagation type is the ANN mostly used for this task. The literature survey shows many authors have used this strategy [3-13]. Also, adaptive resonance theory (ART2) has been used to study the wear propagation [14-16]. Besides neural networks, several other methods have been used to predict tool wear such as support vector machine (SVM) [6,17-19]. Besides ANNs, other methods such as fuzzy logic and neurofuzzy [8,20,21], analytic hierarchy process [22], and group method of data handling (GMDH) can be used [23]. Each method has its pros and cons. The most important question is how to make sure that the system is reliable? In other words, the system should be efficient and effective under test conditions that are unseen during training.

In contrast to the direct measurement method, Astakhov [24] proposed to study the physical process that occurs in the tool-workpiece interface and use it to predict tool wear. Astakhov indicated that, stress (normal and shear) are not the only reason to cause the tool wear in the flank contact face; a plastic deformation of the cutting wedge, called plastic lowering, is a major cause in the tool failure. In studying the contact phenomena of the tool-workpiece interface, the author found “minimum tool wear at optimum cutting speed where the apparent friction coefficient is minimum.”

The last observation in this paper relates the tool geometry with the flank wear. Using inserts of standard materials and shapes enables to have a correlation curve regardless of the work material or the cutting conditions.

Li [25] reviewed the various acoustic emissions sensing (AE) research on tool wear in turning. The AE is an effective indirect method in determining the tool wear. The major gain in using AE is its frequency range, which is much higher than those of the machine vibration and environmental noise. Various signal processing techniques are used to extract the physical features of tool wear. Time series analysis is used with Artificial Neural Network to get the autoregressive parameter (AR) and AR residual signal to analyze tool wear. It is found that the power of residual signal of AE increases with the increase of flank wear. Fourier Transform (FT) proves that the magnitude of AE in the frequency domain is sensitive to the change in the tool wear. The drawback of FT is the fact that it deals with AE as stationary signal, which it is not. This will lead to average the signal on that duration. Unlike FT, Gabor Transform (GT) deals with non-

stationary signals as a short data window. But it can not deal with signals of patterns with different scales. The last technique is Wavelet Transform. It is able to detect and extract the AE feature to gradually increase in flank wear.

Arul et al. [26] used AE sensing to study the effect of drilling parameters on thrust force and flank wear using glass fiber reinforced plastic composites as workpiece. It was found that the thrust force is affected by the feed rate significantly compared to the cutting speed. Also, the minimum tool wear is associated with the optimum cutting conditions, and tool wear is proportional to drill feed. During, drilling the workpiece emits acoustic emission signals due to breakage of fiber glass. These signals are used to monitor the AE RMS values. The AE RMS values increases with increasing cutting speed to a certain level, after that it starts to decrease.

Sun et al. [16] presented the importance of the careful selection for the training data sets in ANN. It is important to extract the characteristic of tool wear process and ignore the irrelevant data, without compromising the generalization accuracy. The study was carried out using an AE sensor and cutting force sensor. To obtain the efficient data in tool condition monitoring support vector machine (SVM) is used. SVM has the ability to select and reject sample data. In addition, the generalization error is categorized into three regions, where each region gives an indication about how much the samples contribute to the decision making. Each of these regions has certain factor that ignores the irrelevant data. This technique is able to select an efficient training set that is fast in performance without trading off the accuracy.

Lu and Asibu [27] presented the tool wear based on the sound generated during turning process. Also, a dynamical model is established to relate the tool wear with the sound signal generated from the cutting process. The asperities on the tool and the work piece considered as source of exciting the system to generate sound signals. The asperities are modeled as trapezoidal series that have height, spacing and size. It was found that as the parameters of the asperities decrease the flank wear increases and signals shift to higher frequencies.

Wong et al. [13] studied different ANNs for machinability data representation. Both feed-forward and back propagation were used. The former was used to predict the best machining parameters, while the latter was used to train the network. In the feed-

forward mode a new neuron is introduced. This neuron is a product neuron for non-linear input which is the depth of cut. Unlike the classical neuron, summation neuron, product neuron can have multiple neurons but weighted once. This will boost the processing of a signal coming from a product neuron comparing to a summation neuron. The authors introduce a new method to train the neurons, called Reinforced Retraining (RR). It forces the solution away from local or weak minima towards global minima. Combining Steep Decent and RR methods converges into global minima eight times faster than Variable Learning Rate. It was proven that non linear neuron network is better than classical neuron network.

Sun et al. [19] presented the support vector machine (SVM) as strategy for NN learning for different cutting conditions. SVM is used to evaluate the set of AE data and to extract and differentiate relevant data during cutting process. This work not only focuses on the relevant data but also it selects the minimum set of features. In the experiment, 25% of data patterns were used in the training set, and 75% of data patterns were used in the testing set. This allows for covering all cutting range and tool conditions to study effectiveness of this feature selection process in tool condition monitoring.

Ghosh et al. [7] presented an ANN-based sensor fusion model for tool condition monitoring (TCM) for a face milling process. Flank wear was predicted using sensor fusion technique, from extracted features cutting forces, spindle vibration, spindle current, and sound pressure. In face milling only when the cutting tool is in contact with the work-piece signals carry useful data on cutting tool condition. Therefore, it is important to extract the relevant data. Beside the forces, current, voltage and input power are good source of information about the tool wear. It was noticed that TCM based on power is reliable comparing to force based using dynamometer.

Dimla and Lister [12] used ANN to predict tool condition online. This method added intermediate classifications for the tool between the end states of “worn” or “sharp”. This gives more reliability for the system and reduces the cost. Attempts to study the effects of changing the cutting conditions, such as tool materials and cutting area, on the ANN, revealed that the ANN was not able to adapt the new settings.

Samanta et. al. [6] compare ANN and SVM in bearing fault detection. Genetic Algorithms were used, substantially, to decide about the input features and classifier's parameters. Two set of results are obtain, with and without auto-selection of feature selection. Three comparisons were made based on (a) sensor location, (b) signal pre-processing, and (c) number of features. From the results obtained, SVM was better in performance and in time required for training. Kuo [10] combine ANN and Fuzzy logic to estimate tool wear using multi sensors inputs (force, vibration, and acoustic). Time series and frequency analyzer were used to extract features. Then, these extracted features were used as inputs for Error Back-Propagation Network (EBPN) and Counter-Propagation Network (CPN) analyzer. Results showed EBPN forecasts better that CPN, yet it required longer training time. When using multi-sensors, FNN can predict tool wear better than multiple regression and ANN and less time required for training. Kuo found out that non-uniformly distributed hardness of work piece causes unpredictable amount tool wear.

Silva et al[14] used a hybrid AI system that consist of two ANNs, namely self-organizing map (SOM) and adaptive resonance theory (ART), linked with a fuzzy logic to monitor tool wear. The fuzzy functions are used to compare the prediction of the two ANNs, in order to decide which one is more reliable. SOM showed better feature extraction than ART, however, it needs longer training time. Taylor filter was used to sort out the misclassification from the ANN due to the noise detected by the sensors. Li et al [29] studied the tool wear and cutting force relation using coated carbide inserts, while using vertical milling machine. The results showed that flank wear, which was the major reason for tool failure, is more significant in the up milling than in the down milling. The force generated was affected by the tool wear as well as the thermal effect due to the frictional engagement between the insert and the workpiece during cutting. Sikdar and Chen [30] presented the relationship between the flank wear area and the cutting forces in turning operation. They found that the more the flank wear the higher the friction between the tool and the workpiece, which leads to increase in the forces magnitude in all directions. The rate of change in the axial and radial force components was found to be higher than the tangential one when the tool is about to fail. They also found radial force

is larger than the axial one when the tool begins to fail. A mathematical model was developed to understand the relation between flank wear and cutting forces.

Huang et al [31] presented a fault detection and diagnosis based on an observer model for CNC milling center. This model was used to predict tool wear with relation to the cutting forces. Tool wear is considered to be a state variable, and cutting forces and other variable to be observed. A dynamometer was used to measure cutting forces and a camera system was mounted to visualize tool wear. The authors indicated that this observer is limited to the same setup used in their test. This means for any deviations in the material or cutting tool the model is not valid anymore. This restriction made the system to be identified each time a new material or inserts is used.

Oraby and Hayhurst [32] tried to avoid the machining parameters in determining tool life for center lathe machine. They studied the tool life using non-linear analysis technique based on the forces ratios. A model for measuring tool wear and another one for tool life are developed, based of force ratios. The model demonstrated a good prediction capability and good agreement with the results from the experiments.

Choudhury and Kishore [33] presented in their work a mathematical model to relate flank wear with the ratio of feed force to cutting force. Flank wear increased linearly with the increase in machining parameters and the diameter of the workpeice.

Santanu and Chattopadhyay [21] applied Analytic Hierarchy Process model to predict the tool status during machining, and to tell in what category the tool is; sharp, workable, or worn out. The cutting forces and flank wear were used to formulate this model. This method was able to estimate the state of tool wear, however, some cases of overlapping between categories occurred.

Li et al [20] presented different approach for tool monitoring through estimating the cutting force using a current sensor installed in the ac servomotor for the CNC turning machine. Using neuro-fuzzy inference system this measurements can be structured to detect tool wear. This method focuses mainly in the last stage of the tool wear, when the tool reaches its useful life. This method is not applicable for light cuts.

Choudhury and Rath [34] investigated, in milling, the relation between the flank wear and the tangential force coefficient and other cutting parameters to estimate tool wear. A mathematical model, using least square model, was developed to find tool wear. The

results showed increase in the tool wear with the increase in depth of cut and feed. Cutting speed had negligible effect on the tangential force coefficient.

2.5 Summary

This chapter gives a general background about tool wear in cutting tools and the nature of the acoustic emission generated during machining and its types. The chapter also reviews many of the classification methods used in machine condition monitoring. The experimental setup and methodology is presented in the next chapter.

CHAPTER 3: DATA COLLECTION AND EXPERIMENTAL WORK

3.1 Experimental setup

In this machining experiment, mild steel is chosen as a workpiece material. The workpiece dimensions are 300mm in length and 80mm in diameter. Mild steel contains a low amount of carbon, which makes it neither extremely brittle nor ductile, significant amount of manganese along with lesser amount of phosphorus and sulfur. The chemical composition and mechanical properties of the material are given in Table 1.

Table 1: Specification of workpiece [35]

C	0.15-0.2%
Mn	0.6-0.9%
P	0.04%
S	0.05%
Tensile strength	634MPa
Yield strength	386MPa
Hardness	197HB

The cutting experiments were carried out on a CNC lathe machine using coated carbide inserts. A platform kistler dynamometer, attached to the tool holder, is used to measure the cutting forces in the three directions, namely tangential, axial (feed) and radial forces. Figure 6 shows the experimental setup, the piezoelectric AE sensor, kistler model 815B, is placed on the upper surface of the dynamometer using powerful magnetic clamp.

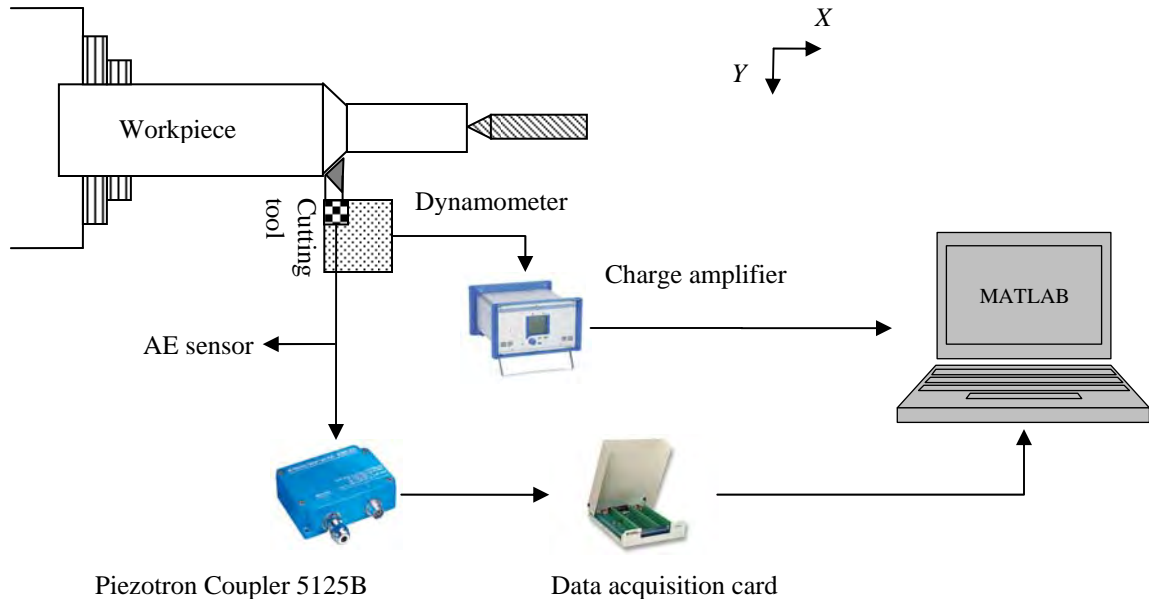

Figure 6: Experimental set up

3.2 Experimental procedure

According to the design of experiments, the three main machining parameters (cutting speed, feed, depth of cut) are set according to their effect on the tool wear. Five levels of cutting speed, three levels of feed rate, and one level of depth of cut, are listed in Table 2. Since depth of cut has the least effect on tool wear, it kept constant. This will comprehensively cover the entire parameter space with precise and concise results.

Table 2: Machining parameters

Levels	Cutting speed (v ,m/min)	Feed rate (f ,mm/rev)	Depth of cut (d ,mm)
1	110	0.15	1
2	130	0.2	
3	150	0.3	
4	170		
5	190		

Initial runs are carried out at different machining parameters as presented in Table 2 using a fresh cutting tool. These runs are to examine the effect of machining parameters on the signals acquired. Next, runs are conducted to achieve progressive tool wear conditions.

A tool conditioning monitoring setup, with the characteristics shown in Table 3, employing MATLAB software [36], is used for acquiring the sensory signals. In each run, all the sensory signals from the three cutting forces in the feed, radial and tangential cutting directions are measured, using the dynamometer with Kistler Type 9251A force transducer. Cutting force is used to estimate tool wear and the actual cutting force is measured by a force dynamometer at a sampling rate of 1 kHz. The three components of the cutting force are amplified with Kistler type 5070 charge amplifier and then plotted using Daynoware software [37]. At the same time, the continuous AE signals are also recorded, using Kistler Type 8152A. In order to avoid signal attenuation, the AE sensor should be placed as close to the cutting zone as possible as described in [38].

Table 3: Machining monitoring setup

Sensors

Cutting Forces

3 x 9251A Kistler quartz force sensor

3 x 1 Channel Kistler 5070 charge amplifier

Acoustic emission

AE sensor Kistler 815B

Kistler 5152B2 coupler

Acquisition board and software

National Instruments PCI-6132

MATLAB 7.2

Prior to machining runs, Nielsen-Hsu method [39, 40], or pencil lead break test, is performed. This test checks the transmission of AE signal in workpiece and tool material. The piezoelectric AE sensor detects signals above 50 kHz and up to 400 kHz. To minimize the influence of noise signals and aliasing errors, signals coming out of the AE

sensors are passed through an AE band-pass filter (Piezotron Coupler 5125B) between 200 kHz and 1 MHz. The band-pass filter reduces the influence of disturbances such as noise or other non-measurable contributions [41]. The amplifier has a gain of 20/40 dB. This gain must be small as possible to avoid any signal distortions [39]. The signals are sampled using National Instruments data acquisition card at 1.5 MHz sampling frequency. Then the data are transferred to and stored in the PC. Runs are periodically interrupted, the coated carbide insert is taken out of the tool holder, and tool wear is measured using a microscope. Maximum flank wear is recorded. This procedure is continued, in steps of two seconds of machining, until the tool wear reaches around 0.8 mm.

3.3 Signal pre-treatment

In industrial environment, a combination of mechanical, electrical, and acoustic signals are highly present in signals acquired from any machining center, whether it is during machining time or off machining. In turning, useful information about tool status is only acquired when the tool is in direct contact with the workpiece. Therefore, to have reliable tool wear monitoring a signal pretreatment is essential, before extracting features.

It is important to extract the part of the acquired signal during the time the tool is actually removing material, since this part only encloses information about the tool life. Force and AE sensors start acquiring signals few seconds before tool-workpiece engagement and stay few seconds after disengagement. Therefore, the first step is to remove the non-machining signal part, which may exist at either ends of both force and AE signals. Figure 7 depicts this procedure for one force signal before and after treatment. The arrows indicate where the actual cutting starts and ends.

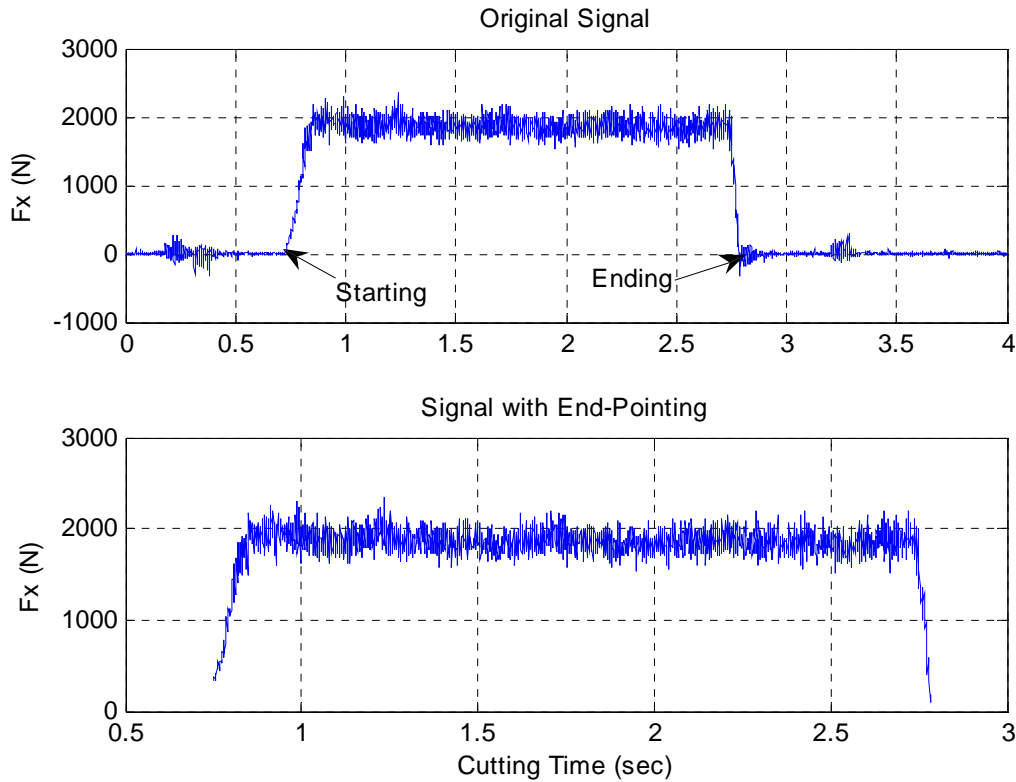

Figure 7: Force signal pre-treatment

Whereas the cutting force signal needs only removal of non-machining part from both signal ends, AE signal needs further treatment. As mentioned earlier, during machining continuous AE signal gives information about tool wear. However, AE signals combine both continuous and transient information. Some burst signals with high peak amplitude, not related to tool wear, are due to the friction between the tool and workpiece. Hence, it is mandatory to eliminate these burst from AE signal to have true information about tool wear. To do this, a floating threshold value [20] that is higher than the AE mean signal level is defined. Any part of the signal crossing this value is considered transient and is filtered out of the continuous AE signal. Values below the floating point gives information about tool wear and is used in the analysis. Figure 8 shows part of original and filtered AE signals.

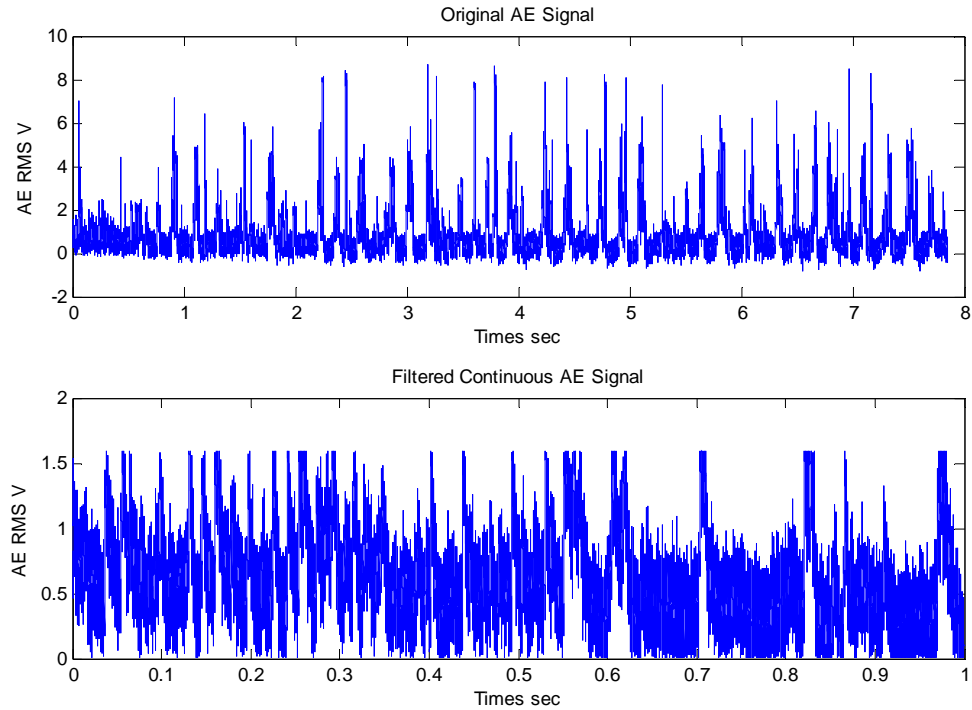

Figure 8: AE signals pre-treatment

3.4 Summary

This chapter presented the setup used to carry out the experimental runs. Integration between hardware and software platforms is provided. Machining parameters and conditions to be covered are determined in a way to give a wide range of tool wear possibilities. The next chapter describes how to utilize the acquired signals and how to correlate them with tool wear levels.

CHAPTER 4: MODELING AND SIMULATION OF TOOL WEAR USING ANN AND PC

4.1 Introduction

Classifying the wear state of a cutting tool is a classical and yet unsolved problem in manufacturing. Hence, it is mandatory to incorporate some degree of artificial intelligence in metal cutting machines. The efficiency of the machine intelligence determines the reliability of the tool wear monitoring system and should be able to reform the relationship between the parameters monitored and the tool wear propagation as these parameters change. In this sense, the system should be able to generalize, i.e. to predict reasonable tool wear values for parameters not encountered.

4.2 Feature extraction

As indicating in the system architecture diagram, Figure 6, sensory signals patterns are related at the end to the state of the tool. Therefore, it is important to build a relationship between signal patterns and tool wear. It is clear that the collected signals will have a certain level of redundancy and randomness that bear no useful information about the classification of the signal. In this sense it is important to create a system which is able to extract features that are concise and representative of the relevant information in the signal. This task in tool wear monitoring is crucial and challenging. Different signal processing techniques can be used to extract features from the sensory signal. Extracting features from signals should be simple and meaningful. In other words, it should not be too computationally intensive and feature vectors should be well correlated. Two major domains are used in feature extraction: time domain and frequency domain. Very often, the two domains are combined [10,14-17,19,23]. Most commonly used are time series analysis, fast Fourier transform (FFT), and wavelet transform. Time series analysis is used in this thesis. In cutting force signals, average values, RMS values, changes in signal levels such as increments or decrements [42, 43], the ratio of different cutting force components [32,33,45] and much more are used as

time series features in previous publications. Parameters of probability distributions (statistical features), which is an important class of time domain, is implanted. Previous studies have shown that statistical features can be indicative of tool wear [46-49]. A change in statistical features corresponds to a change in the tool wear. The following statistical features are extracted from a sensory signal: mean, standard deviation, variance, kurtosis and skewness. A brief mathematical description of these features follows:

The mean value \bar{x} of a signal $x(t)$ over an interval T is

$$\bar{x} = \frac{\int_0^T x(t) dt}{T}$$

The standard deviation σ of a signal $x(t)$ over an interval T is

$$\sigma = \sqrt{\frac{1}{T} \int_0^T (x(t) - \bar{x})^2 dt}$$

The variance σ^2 of a signal $x(t)$ over an interval T is

$$\sigma^2 = \frac{1}{T} \int_0^T (x(t) - \bar{x})^2 dt$$

The kurtosis K of a signal $x(t)$ over an interval T is

$$K = \frac{1}{\sigma^4 T} \int_0^T x^4 dt$$

The skewness S of a signal $x(t)$ over an interval T is

$$S = \frac{1}{\sigma^3 T} \int_0^T x^3 dt$$

Other classes of time domain, which are beyond the scope of this thesis, are presented in previous studies [47-54]. Coefficients of a time series model which is used to describe the measured signal such as autoregressive (AR), moving average (MA), and autoregressive moving average (ARMA) are used as features to predict tool wear [10, 48,

49]. A number of model coefficients can be chosen based on the model order. Signal characteristics are represented using these model coefficients.

Fast Fourier transform (FFT) has been used extensively in spectral analysis [50-52]. The power level of a signal in different spectral band is indicative for tool wear change. FFT shows great results in the frequency domain but it is not efficient in the time domain and loses signal information. To overcome this, a new technique in signal processing has been proposed. It is the wavelet analysis. It has been previously applied to monitoring of machining process with great success [9,53,54]. Wavelet analysis is able to deal with discontinuities in higher derivative, breakdown point, and self-similarity. In this sense, with wavelet analysis more information about tool status can be obtained.

4.2.1 Feature assessment criteria

Principal components analysis (PCA), also known as Karhunen-Loeve transformation [18], is used extensively in feature extraction from high dimensional data set with interrelated variables [55-59]. It shows high ability in eliminating redundant and irrelevant information in any signal. Neuroscience, face recognition and image compression are high dimensional and complex systems. In such systems, where sensory signal are equivocal, redundant and inexplicit, PCA provides efficient way to extract the most relevant features. Too many variables can be delusive and awkward. This simple technique is an ideal solution to reduce dimensionality without loss of information.

Transforming highly dimensional and correlated data set to new coordinate system produces a new set, uncorrelated and smaller in size, of variables [60]. This new set is the principal components. It retains as much as possible of the variation in the original data.

In general [56], sensory signal is represented in data matrix X , representing M observations of N variables as

$$X = \begin{bmatrix} x_{11} & x_{12} & \dots & x_{1N} \\ x_{21} & x_{22} & \dots & x_{2N} \\ \vdots & \vdots & \dots & \vdots \\ x_{M1} & x_{M2} & \dots & x_{MN} \end{bmatrix},$$

With a known covariance matrix Σ .

A linear function, $\delta_1^T X$ that has maximum variance, is presented such that δ_1 is a vector of N constants $\delta_{11}, \delta_{12}, \dots, \delta_{1N}$, so that

$$\delta_1^T X = \delta_{11}x_{11} + \delta_{12}x_{12} + \delta_{13}x_{13} + \dots + \delta_{1N}x_{1N} = \sum_{i=1}^N \delta_{1i}x_{1i}$$

Where δ_i is an eigenvector for Σ corresponding to its eigenvalue λ_i . Another linear function $\delta_2^T X$ is presented, which is uncorrelated with the previous one, $\delta_1^T X$. These steps are stopped when the linear function $\delta_N^T X$ is computed. $\delta_N^T X$ should have a maximum variance, which is uncorrelated with $\delta_1^T X, \delta_2^T X, \dots, \delta_{N-1}^T X$. These linear functions are the principal components (PC). Although N PCs can be computed, a much lower number should be sufficient to represent most of the variation in the original data [60]. Derivations for the first principal component is presented next; for further information please refer to [55, 60].

As stated above, the linear function $\delta_1^T X$ must maximize the variation in the data set. Therefore the vector δ_1 maximizes the variance of the projections in the new coordinate system, $Var(\delta_1^T X) = \delta_1^T X \delta_1$. This optimization derivation is true if the sum of squares of elements of δ_1 equals to one, i.e. $\delta_1^T \delta_1 = 1$. Lagrange multipliers, λ , ensure this maximization.

$$L(\delta_1, \lambda) = \delta_1^T \Sigma \delta_1 - \lambda(\delta_1^T \delta_1 - 1)$$

Differentiating with respect to δ_1

$$\Sigma \delta_1 - \lambda \delta_1 = 0 \quad \rightarrow \quad (\Sigma - \lambda I_N) \delta_1 = 0$$

Where I_N is an identity matrix. This proves, δ_1 is the largest eigenvector corresponding the largest eigenvalue of Σ . In addition, λ is the largest eigenvalue.

In short, the principle component of X is $\delta_i^T X$, where $i = 1, 2, \dots, N$, N being the size of the data set. $Var(\delta_i^T X) = \lambda_i$, where λ_i is the i^{th} largest eigenvalue of Σ , and δ_i is the corresponding eigenvector.

4.3 Modeling strategy

Modeling or decision-making strategies which have been used in this work, for controlling the machining process are discussed in this section. Modeling strategies are divided into two categories: discriminative and generative models. The latter is out of the scope of this work. Discriminative model minimizes the error of a training sampling data. It creates the boundary between classes of data. This is easier than trying to find the variation within one sample. This gives the privilege, for discriminative models, of having the highest performance in classification problems. Multilayer perceptrons (MLP) and polynomial classifier (PC) are discriminative models implemented in this investigation.

4.3.1 Neural network

An artificial neural networks (ANN) operates in the same way of human brain. Numerous and tremendous applications of artificial neural networks have been applied in science, mathematics, medicine, and business as well. ANN consists of a number of structural constituents called neurons. A neuron has the ability to perform fast computations such as pattern recognition. Figure 9 shows a model of a neuron. The three basic element of a neuron are [56]:

- A set of synapses characterized by a weight or strength of its own.
- An adder for summing the input signals weighted by respective synapses of the neuron.
- An activation function for limiting the amplitude of the output of a neuron.

Among different architectural models of neural networks, multi-layer perceptrons of back-propagation type is most used [61,62]. Basically, MLPs consist of three major layers, namely, input layer, hidden layer, and output layer. The input signal propagates in the forward direction in each layer. Back-propagation neural network (BPNN) uses the error-correction learning rule where the error signal propagate thorough the network in the backward direction against the direction of synaptic connections in order to adjust the weight. Thus, the name back- propagation. Figure 10 shows the architectural structure of multi-layer perceptrons.

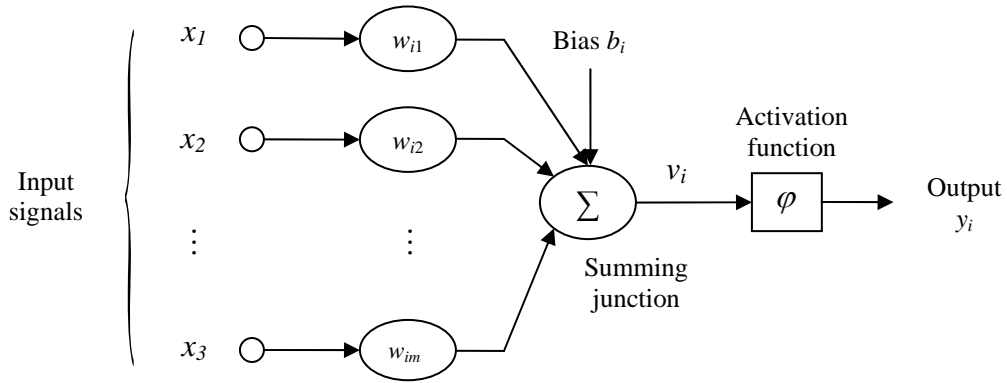

Figure 9: Nonlinear model of a neuron

For a neuron i , Figure 9 can be expressed in mathematical terms

$$u_i = \sum_{j=1}^m w_{ij} x_j$$

and

$$y_i = \varphi(u_i + b_i)$$

where x_1, x_2, \dots, x_m are input signals; $w_{i1}, w_{i2}, \dots, w_{im}$ are the synaptic weights of neuron i ; b_i is the bias; u_i is the linear combiner output; φ is the activation function which can be a hyperbolic tangent or sigmoid. The latter is used in this study. And y_i is the output signal which is the tool wear in this study. Knowing the basic parameters of single neuron the output of BPNN can be obtained as follows:

$$Y_i = \frac{1}{1 + e^{-v_i}}$$

The error signal at the output of the i -th neuron of n iteration is

$$e_i(n) = d_i(n) - y_i(n)$$

where $d_j(n)$ and $y_j(n)$ are the desired response of neuron j and the actual output of the same neuron, respectively. An instantaneous error energy for the same neuron is defined as $\frac{1}{2}e_j^2(n)$. To obtain the total error energy over all the neurons take the summation of all the neurons in the output layer as

$$\mathfrak{R}(n) = \frac{1}{2} \sum_{i \in D} e_i^2(n)$$

where the set D includes all the neurons in the output layer. Then, the error back-propagate through the network to adjust the weights until an acceptable error tolerance is achieved through training process. The weights are adjusted by the following amount

$$\Delta w_{ij}(n) = -\gamma \frac{\partial \mathfrak{R}(n)}{\partial w_{ij}(n)}$$

where γ is the learning rate parameter of the back-propagation algorithm.

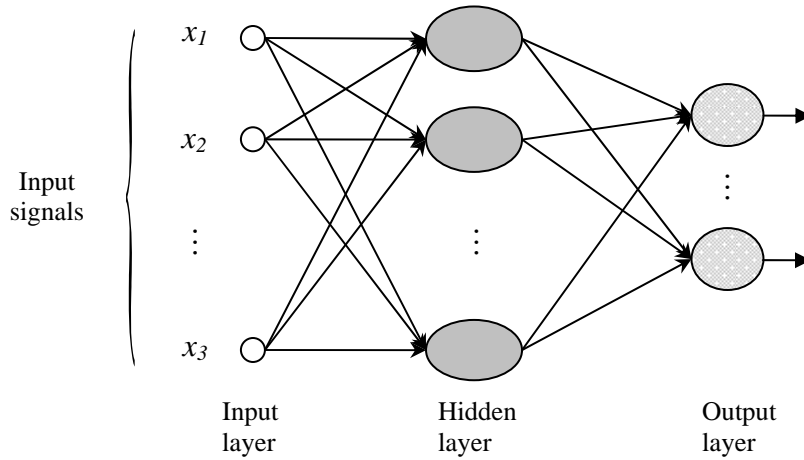

Figure 10: Architectural graph of MLP

4.3.2 Polynomial classifier

Polynomial classifier is considered as a discriminative model [63]. In the classifier, the input vectors (feature vectors) are represented as x_1, \dots, x_N . They are the basis terms of a high dimensional polynomial vector, $\phi(x)$. To illustrate more, for second order polynomial input vector, say, $x = [x_1 \ x_2]^t$ then $\phi(x) = [1 \ x_1 \ x_2 \ x_1^2 \ x_1x_2 \ x_2^2]^t$. These terms are of the form $x_{i_1}x_{i_2}\dots x_{i_k}$ where k is less of equal to the polynomial degree. Figure 11 shows polynomial classifier using two-dimensional feature vector.

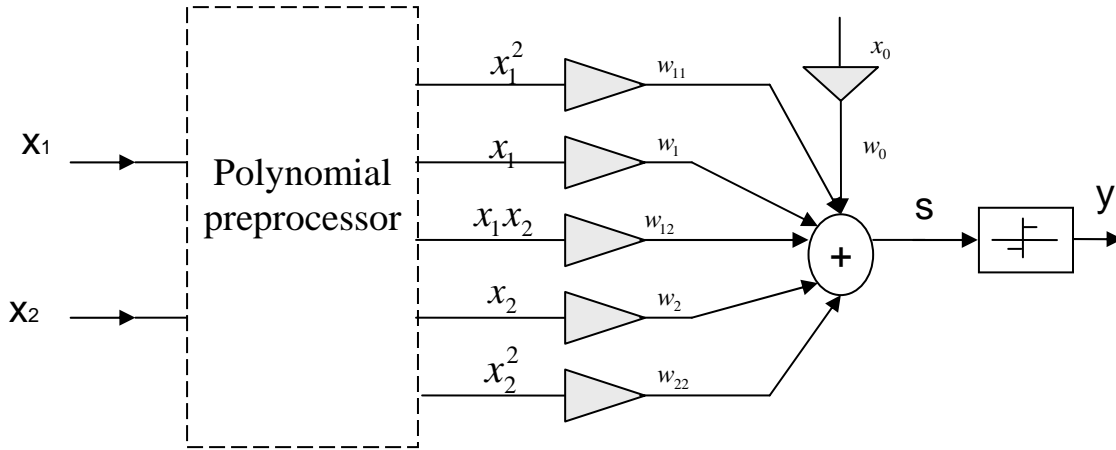

Figure 11: Architectural graph of polynomial classifier

The main aim of the classifier is to distinguish the input vector of relevant data $\phi(x^{rel})$, from those of the irrelevant data $\phi(x^{irrel})$ in the polynomial vector $\phi(x)$. In other words, creating the boundary. This can be done using the following inner product $\phi(x_i) \cdot w$, where w are adjustable parameter to create a hyper plane in $\phi(x)$. This product produces a score for each x_i , and is then averaged. The total score will be $s = \frac{1}{N} \sum_{i=1}^N \phi(x_i) \cdot w$. The desired output of the classifier is one for the relevant data vectors and zero for irrelevant data vectors.

The mean-square error is used to classify the outputs, and to compare the actual and the desired output. It is important to keep this error as minimum as possible, in this case the optimum conditions are obtained. Mean-square error calculated as

$$w_o = \arg \min_w \left[\sum_{i=1}^{N_{rel}} |\phi(x_i)w - 1|^2 + \sum_{i=1}^{N_{irrel}} |\phi(x_i)w|^2 \right]$$

Where N_{rel} and N_{irrel} are the data of relevant data and irrelevant data respectively.

The training procedure can be formulated using matrix form. M_{rel} is a matrix with rows of the polynomial expansion of the relevant data (feature inputs).

$$M_{rel} = \begin{bmatrix} \phi(x_1)^t \\ \phi(x_1)^t \\ \vdots \\ \phi(x_{N_{rel}})^t \end{bmatrix}$$

In the same way the matrix for irrelevant data is

$$M_{irrel} = \begin{bmatrix} \phi(x_1)^t \\ \phi(x_1)^t \\ \vdots \\ \phi(x_{N_{irrel}})^t \end{bmatrix}$$

Then to combine both matrices

$$M = \begin{bmatrix} M_{rel} \\ M_{irrel} \end{bmatrix}$$

Then mean-square error becomes

$$w_o = \arg \min_w \|Mw - o\|_2$$

Where o is the ideal output. This means it contains N_{rel} ones then N_{irrel} zeros. To solve the above equation use the normal equation method

$$M^t M W = M^t o$$

Expand it to be

$$\left(M_{rel}^t M_{rel} + M_{irrel}^t M_{irrel} \right) W = M_{rel}^t \mathbf{1}$$

Where $\mathbf{1}$ is a vector of ones. Let $R = M_{rel}^t M_{rel} + M_{irrel}^t M_{irrel}$, then

$$R W = M_{rel}^t \mathbf{1}$$

R can be decomposed into R_{rel} and R_{irrel} . This approach is constructive in classification problem, since the two components of R (R_{rel} and R_{irrel}) do not change with respect to the training data set. Evaluating these two matrices is the most important part in the computation; hence, both matrices are calculated separately. And the last thing is $M_{rel}^t \mathbf{1}$ is obtained as entries to R_{rel} .

4.3.3 Leave One Out

In classification algorithm, it is important to use as much training data as possible in order to get accurate results [19]. In pattern recognition, the data is divided in to training set and testing set. This means, potential part of the collected data are not involved in the training process. Less data is available. To overcome this, Leave One Out (LOO) method is used. LOO uses all the data available in training and testing. Training in LOO is done using all but one data point, which is used for the testing. In more details, suppose that you have data consist of n feature vectors $z_i = [z_1, z_2, z_3, \dots, z_n]$. Then, LOO trains the pattern recognition techniques n times, leaving out one of the vectors to be tested. Below is a further explanation:

1. First training set $[z_2, z_3, z_4, \dots, z_n]$, test for z_1

2. Second training set $[z_1, z_3, z_4, \dots, z_n]$, test for z_2
3. Third training set $[z_1, z_2, z_4, \dots, z_n]$, test for z_3
- \vdots
- n. Last training set $[z_1, z_2, z_3, \dots, z_{n-1}]$, test for z_n

LOO is applied with feed forward back propagation neural network (LOONN) and the polynomial classifier (LOOPC) to predict and to classify the status of the tool after machining.

4.4 Summary

This chapter presents the statistical features that are extracted from cutting force and acoustic emission signals. Also it introduces the way PCA can judge and evaluate the importance of each feature, then eliminates redundant features. It also reviews the two classification methods used in pattern recognition; from feeding inputs to the classifier all the way to the output result. From the literature review, presented in chapter 2, and to the author knowledge it can be stated polynomial classifier, presented in chapter 4, has never been used in tool wear detection. Next chapter presents the results neural network and polynomial classifier.

CHAPTER 5: RESULTS AND DISCUSSION

5.1 Introduction

A total of 113 experiments are carried out with a coated carbide sharp tool edge. The flank wear appearance is measured intermittently according to the prescribed intervals using an optical microscope. Tool wear commences as a result of a single or a combination of the wear mechanisms mentioned in chapter 1. Unlike the finish cutting process, a gradual uniform flank wear is observable in these experiments due to the large magnitude of depth of cut. It is noticed under the optical microscope that a prominent sticking material, built up edge, of the workpiece formed on the rake face.

Figure 11 depicts typical cutting forces signals in turning operation. Forces in the three directions are presented in the time domain. When the tool engages and disengages with the workpiece significant variations in the values of cutting forces, and little variations during the steady cutting process are noticed. Because the tool is still fresh at the beginning of the cutting, the tool wear has a minor effect on the chip deformation and thickness. Down spikes in the force signals are noticed. This is due to chip braking. As the tool wear developed the chip gets thicker and larger in deformation. This increases the spikes magnitude. As the cutting distance gets longer, this problem becomes more significant and hence the cutting forces increase.

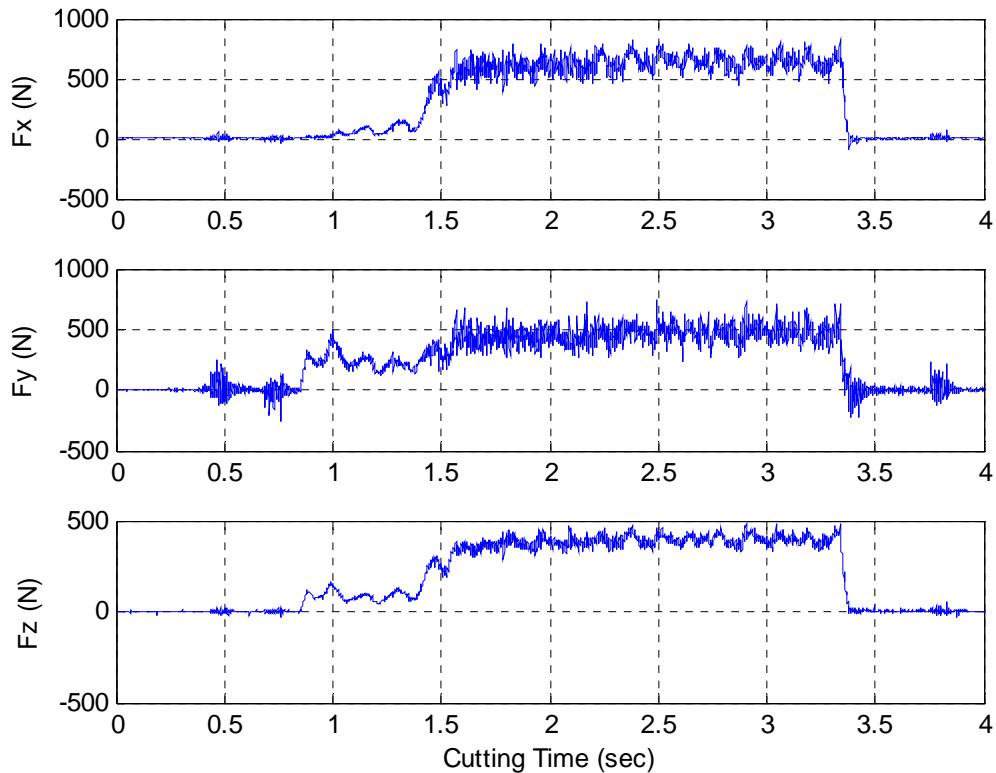

Figure 12: Force signals in the three axes

In Chapter 1, the nature of AE is discussed. Figure 12, shows an AE signal generated while machining. As in the cutting forces signal, a significant variations in the values of AE when tool enters and exits with the workpiece are observed. Continuous and transient signals are recorded from tool wear and chip breakage, respectively. The former, is only used to test gradual wear. Both RMS and raw AE signal are recorded, the latter, contains a very high frequency which make it not feasible to record or analyze [38,45]. Thus, RMS signals are used for the statistical analysis only. AE RMS values can be correlated to the development of wear in tools [19]. The peaks in Figure 12 below are related to the intensity of the source in the material producing an AE signal.

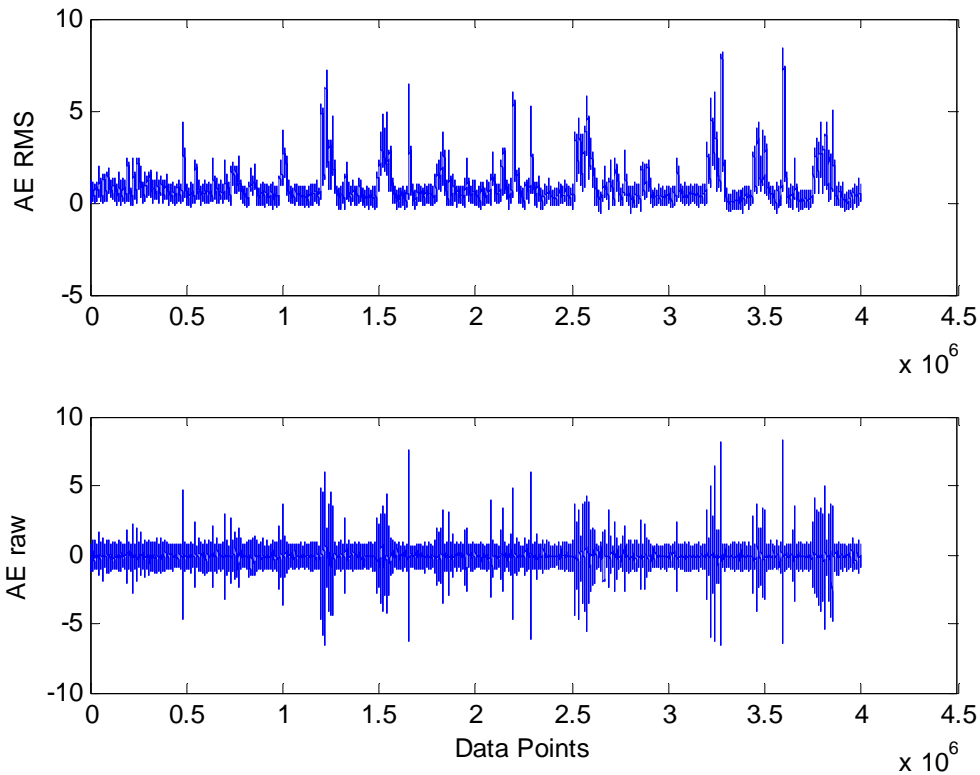

Figure 13: RMS and raw AE signals

The intelligent monitoring system consists of two separate classifiers: back-propagation neural network and polynomial classifier. The former classifier is chosen due to its unsupervised learning capabilities and has demonstrated a great ability in this field in the previous publications [62]. While for the later classifier, to the best of the author knowledge, it has never been used in such application. The main objective of both is to be able to predict the present tool wear. In order to do so, relevant features from cutting force and acoustic emission signals, that correlate with the tool wear most, are to be determined externally and the task of the classifiers is to determine the relationship between the incoming data and the tool wear. As mentioned in chapter 4, in multiple sensory signals, PCA shows efficient way to extract the most relevant statistical features. Among all extracted statistical features, mean and standard deviation of AE signal [19] and the maximum value of the three force components are the most highly correlated with tool wear. The remaining features demonstrated no potential correlation with tool wear.

The AE statistical features are used in PCA in the following order: mean, standard deviation, variance, kurtosis, and skew to generate coefficients for five principal components. Now the original data mapped into the new coordinate system defined by the principal components. The mapped data is the same size as the input data matrix, the AE features in this case. Figure 13 plots of the first two columns of mapped data shows the ratings data projected onto the first two principal components.

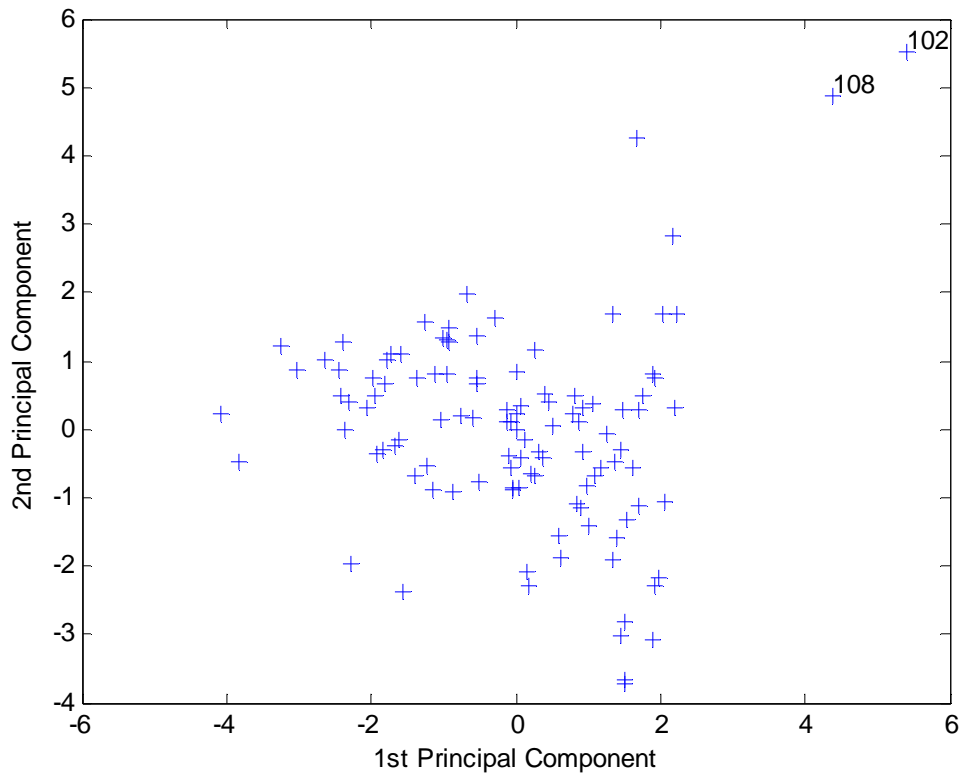

Figure 14: AE data projected in PCA

Note the outlying points in the right half of the plot (points 102 & 108); PCA allows the elimination of some outliers generated from sporadic noisy signals picked up by the sensors. Then, the variance of the new mapped data can be found in order to know which principal component has the highest variability.

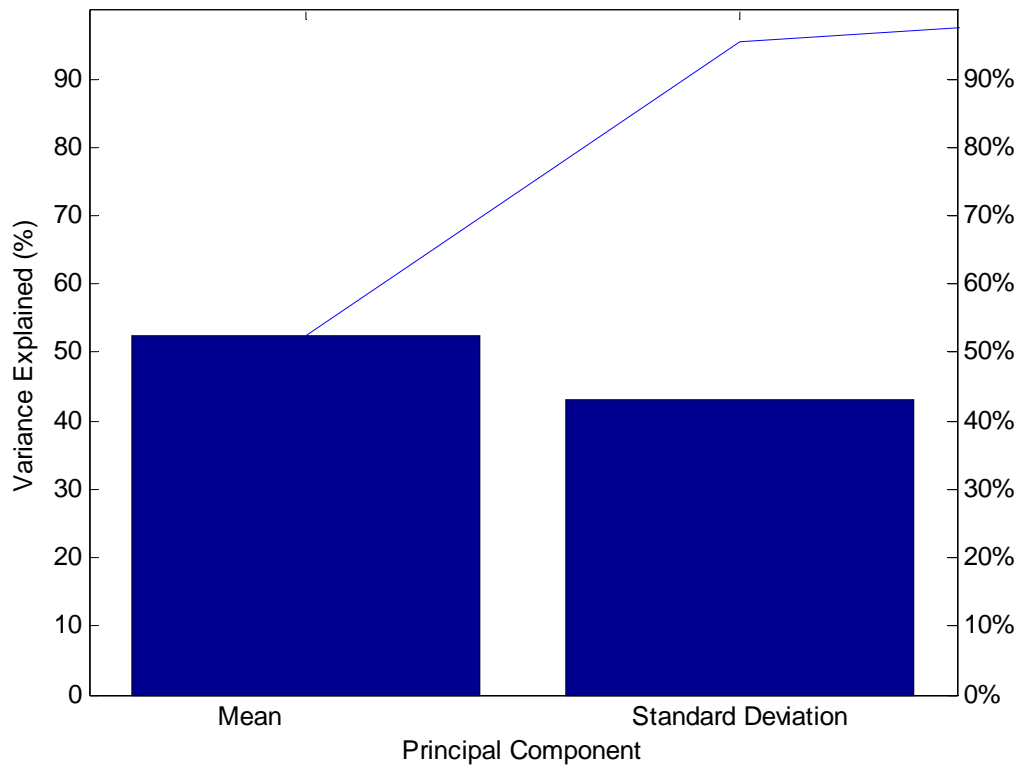

Figure 15: Variation of AE features

The preceding figure shows that the only clear break in the amount of variance accounted for by each component is after the second component. However, the first component by itself explains around 50% of the variance, so more components are probably needed. It can be observed that the first two principal components, which are representing the mean and the standard deviation, explain roughly more than 90% of the total variability in the standardized ratings and the remaining features demonstrated no correlation with tool wear, so that might be a reasonable way to reduce the dimensions in order to visualize the data. Table 4 shows the percent of the total variability explained by each principal component of AE features.

Table 4: Total variability of AE features

AE Feature	Percent of the variability
Mean	52.4443
Standard deviation	43.1631
Variance	3.6279
Kurtosis	0.6617
Skew	0.1031

In the same way, seven cutting force statistical features are used in PCA in the following order: max, mean, median, standard deviation, variance, kurtosis, and skew to generate coefficients for seven principal components. Now the original data mapped into the new coordinate system defined by the principal components. Figure 15 plots of the first two columns of mapped data shows the ratings data projected onto the first two principal components.

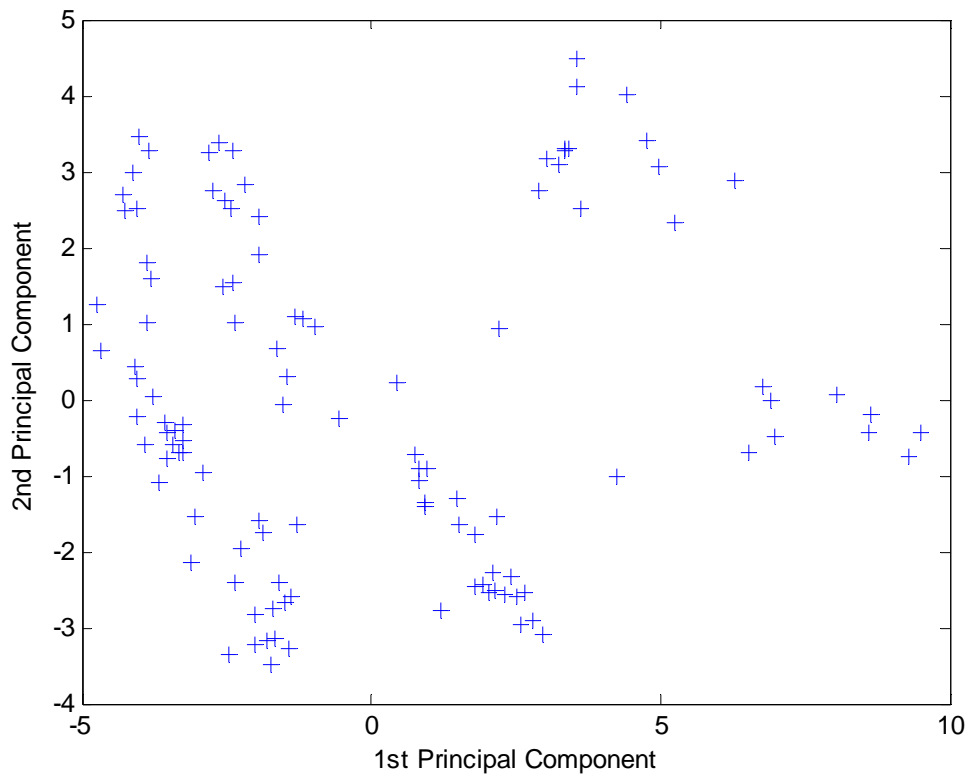

Figure 16: Force data projected in PCA

This data is very scattered and it is not easy to detect or eliminate outliers. The next figure shows the principal components with the highest variability. First component by itself explains around 60% of the variance, so more components are probably needed. It can be shown that the first two principal components explain roughly more than 80% of the total variability in the standardized ratings, so that might be a reasonable way to reduce the dimensions in order to visualize the data. It is decided to use the first three components (maximum value of X , Y , Z cutting force) because they cover almost 90% of the total data.

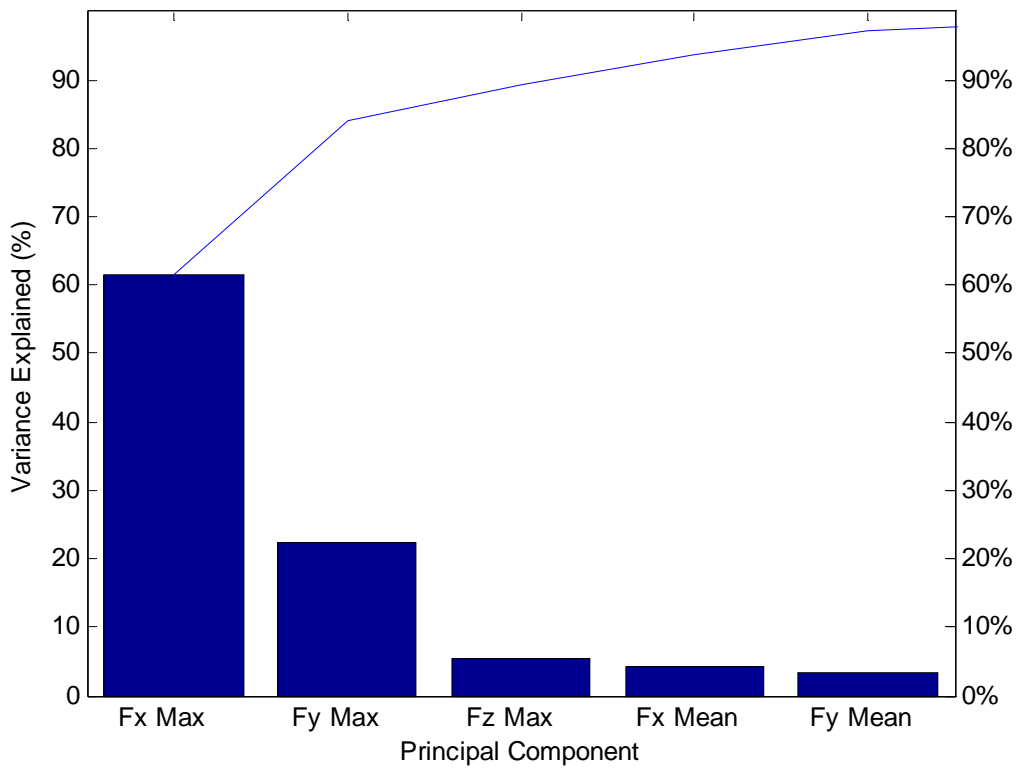

Figure 17: Variation of AE features

5.2 Results from ANN and PC

A clear variation in both sensors output is observed as cutting conditions changed. The features extracted from processing the force and acoustic emission output influence neural network and polynomial classifier performance the most. The measurement of performance for both classifiers consisted simply of the percentage error of the prediction compared with the actual wear value. To visualize the results, plots of prediction results against the measured ones are presented. The average percentage error at each wear level is selected as the final performance measure. The decision making techniques are capable of generalizing over a small range of cutting conditions and this capacity differ between the two classifiers, as will be shown in the following sections.

5.2.1 Results from ANN model

In artificial intelligent decision making strategies, the training data and testing data should cover all of the possible cutting conditions range and tool status so as to validate the effectiveness of this feature selection process. Thus in every trial, data patterns are partitioned into two parts randomly: 25% of data patterns are used in the training set, and 75% of data patterns in the testing set. This partitioning avoids data patterns concentrating on some cutting conditions. All the settings of NN are kept the same in training and testing processes. This ensures accurate comparison for the results. This conventional procedure partitioning method could not produce satisfactory results. Figure 17, demonstrates the results of one prediction run for neural network with average accuracy of 26.85% (the absolute value of the difference between the measured and predicted value divided by the measured value).

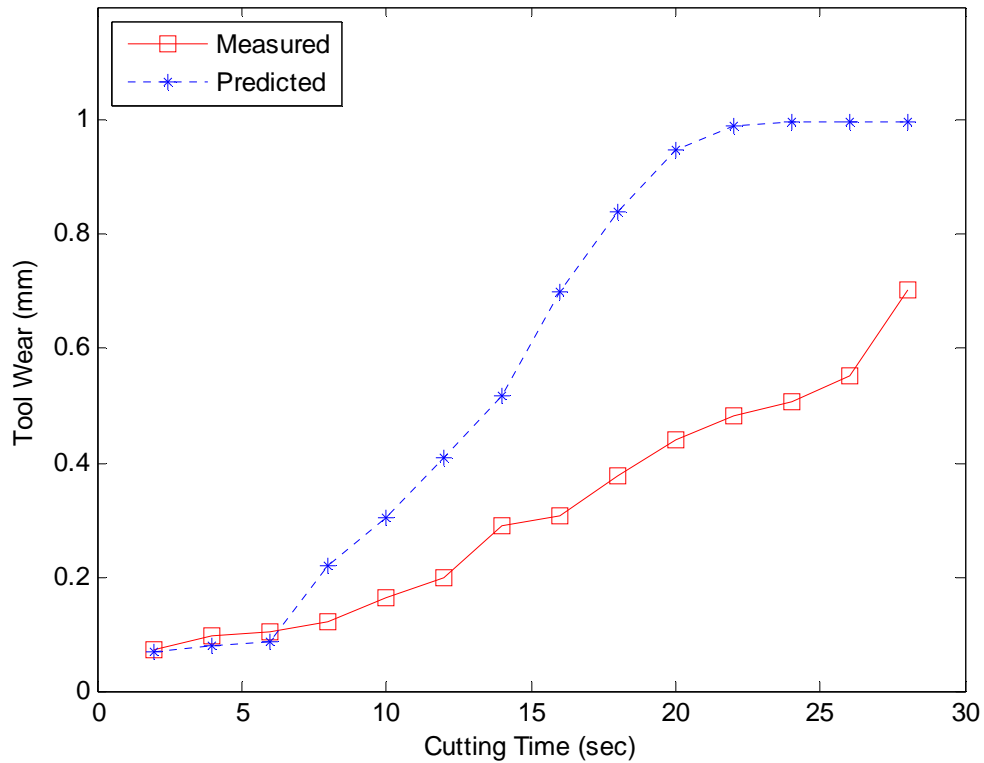

Figure 18: Conventional NN for prediction tool wear

This unsatisfactory result is due to the small size of the available training data points. To increase the accuracy of the system it would be necessary to add more training data, which cover various cutting conditions. Hence, allowing the neural network to learn better the correlated effect of the tool wear and the cutting conditions. This implies, in one hand, to have a large enough training set that reflects a large range of cutting conditions; in the other hand, this requires a large number of experiments in a large cost and time consuming. To improve the performance of the system, without running more experiments, leave one out technique is used. Leave one out enables the system to use all the data points for training and leave one data point for testing.

Three main feature groups are used in the system, namely, cutting conditions features, cutting forces features, and acoustic emissions features. Every group is used in a separate neural network to predict tool wear. The output of each network is multiplied by a certain weight. Weights are chosen using the least square (LS) method. Then, the final tool wear value is the sum of all networks outputs, as shown in Figure 18. The data is normalized so that the distribution of all variables has zero mean and unit covariance.

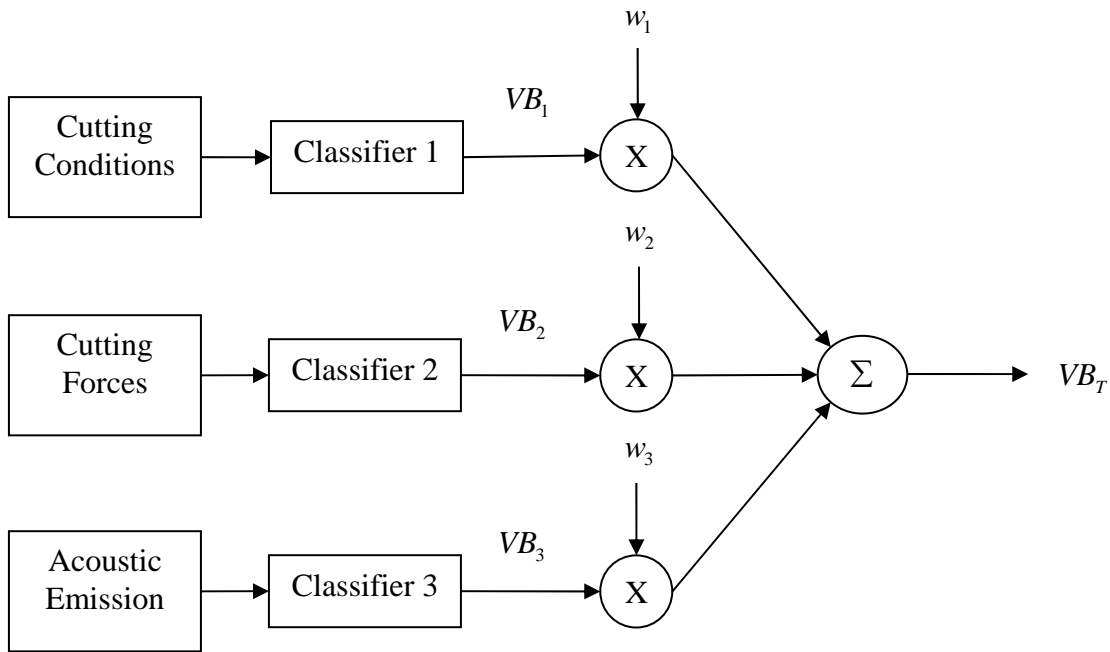

Figure 19: Prediction tool wear using least square

Table 5 presents the features used from machining parameters, cutting force (F_x , F_y , and F_z), and acoustic emission. Features are grouped in six sets as follows

- S1 includes all machining parameters, all cutting force, and all acoustic emission.
S1= [X1,X2,X3,F1,F2,F3,F4,F5,F6,F7,AE1,AE2,AE3,AE4,AE5]
- S2 includes all machining parameters, and all cutting force.
S2= [X1,X2,X3,F1,F2,F3,F4,F5,F6,F7]
- S3 includes all machining parameters, and all acoustic emission.
S3= [X1,X2,X3, AE1,AE2,AE3,AE4,AE5]
- S4 includes all machining parameters, the best cutting force, and the best acoustic emission.
S4= [X1,X2,X3,F1,AE1,AE2]
- S5 includes all machining parameters, the best cutting force
S5= [X1,X2,X3,F1]

- S6 includes all machining parameters, and the best acoustic emission
 $S6 = [X1, X2, X3, AE1, AE2]$

The machining parameters are an essential part among all feature sets. Among the six feature sets, S1 included all extracted features, in addition to the machining parameters, from force and AE signals, and S2 and S3 are separated features of force and AE signals, respectively. Finally, S4 to S6 are the reduced feature sets produced by PCA technique. The eliminated features from S4 to S6 are the ones with very low corresponding PCA parameters. However, this elimination must be verified by corresponding testing sets of the six feature sets, and the testing accuracy provides an indicator of features contribution.

Table 5: Feature list

Index	Description
X1	Cutting speed
X2	Feed rate
X3	Machining time
F1	Force maximum value
F2	Force median value
F3	Force mean value
F4	Force standard deviation
F5	Force variance
F6	Force kurtosis
F7	Force skewness
AE1	Acoustic emission mean value
AE2	Acoustic emission standard deviation
AE3	Acoustic emission variance
AE4	Acoustic emission kurtosis
AE5	Acoustic emission skewness

To compare the learning ability of different feature set, Tables 6-8 show the training and testing results for prediction and classification of tool wear, of three different cutting conditions, of six trials under the feature sets.

Table 6: NN trial 1 (v = 130 m/min, f = 0.15 mm/rev)

Feature set	Training time (s)	Prediction Accuracy	Classification Accuracy
S1	-	87.2 %	100 %
S2	945	86.77 %	100 %
S3	174	86.09 %	90 %
S4	-	85.83 %	90 %
S5	155	84.75 %	100 %
S6	126	84.63 %	100 %

Table 7: NN trial 2 (v = 170 m/min, f = 0.2 mm/rev)

Feature set	Training time (s)	Prediction Accuracy	Classification Accuracy
S1	-	88.13 %	100%
S2	945	87.6 %	100%
S3	174	78.74 %	100%
S4	-	77.25 %	100%
S5	155	76.07 %	100%
S6	126	75.89 %	100 %

Table 8: NN trial 3 (v = 190 m/min, f = 0.15 mm/rev)

Feature set	Training time (s)	Prediction Accuracy	Classification Accuracy
S1	-	93.87 %	100%
S2	945	93.73 %	100%
S3	174	90.35 %	84%
S4	-	91.27 %	84%
S5	155	91.01 %	100%
S6	126	89.44 %	100 %

In Tables 6-8, among the six feature sets S1 shows always the highest prediction accuracy. Thus, it can be concluded that the redundant features, which are eliminated by PCA, may still provide some useful information. However, S1 requires more training time comparing to others. The second column shows the training time. The number of

extracted features determines the computation time requires by the neural networks, therefore the smaller the number of features used as inputs to the neural networks the shorter it takes for decision-making. The over all accuracy of the results is in the range of high 80s and low 90s. S6, in contrast of S1, shows the lowest accuracy. Comparing to other feature set, S6 has the fastest in convergence speed, i.e. it requires the least training time. It is a compromise between better results with slow computation process or slightly lower deceptive results with fast convergence. The last column presents the system capability in classifying the tool state. The tool is identified as fresh or worn. The tool flank wear of 0.3 mm, which is suggested by ISO 3685, is used as a criterion to identify tool state. Flank wear in the fresh tool state is overestimated sometimes by approximately 0.3mm. Over all the system achieve a successful classification percentage of 100% for all worn states.

The following figures presents measured and predicted amount of tool wear through LOONN, using the above sets. Figure 19 presents the results using S1 set as inputs. A good matching between measured and predicted values is noticed. Cutting speed $v=150$ m/min, feed rate $f = 0.15$ m/rev, depth of cut $d = 1$ mm. Average accuracy is 92.04%. While Figure 20 presents tool wear prediction using S4 set. Cutting speed $v=170$ m/min, feed rate $f = 0.15$ m/rev, depth of cut $d = 1$ mm. Average accuracy is 89.02%. Figure 22 presents tool wear prediction using S6 set. Cutting speed $v=150$ m/min, feed rate $f = 0.15$ m/rev, depth of cut $d = 1$ mm. Average accuracy is 90.07 Figure 23 presents tool wear prediction using S6 set. Cutting speed $v=170$ m/min, feed rate $f = 0.15$ m/rev, depth of cut $d = 1$ mm. Average accuracy is 85.1%.

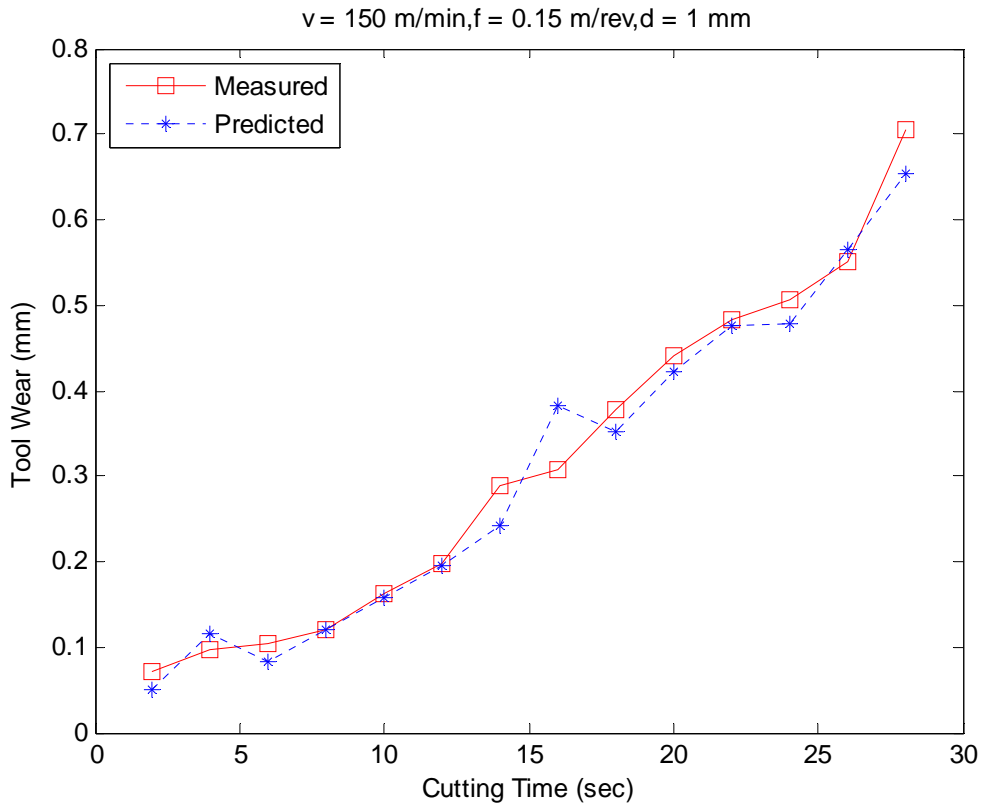

Figure 20: Measured and predicted tool wear through LOONN using S1 set

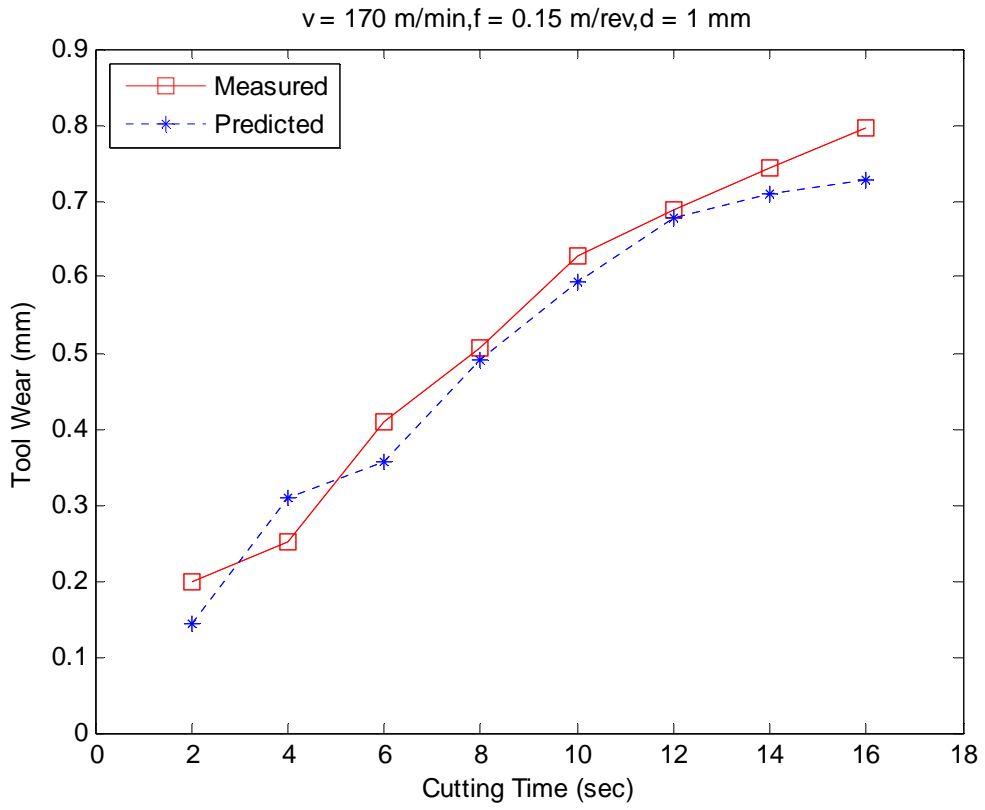

Figure 21: Measured and predicted tool wear through LOONN using S4 set

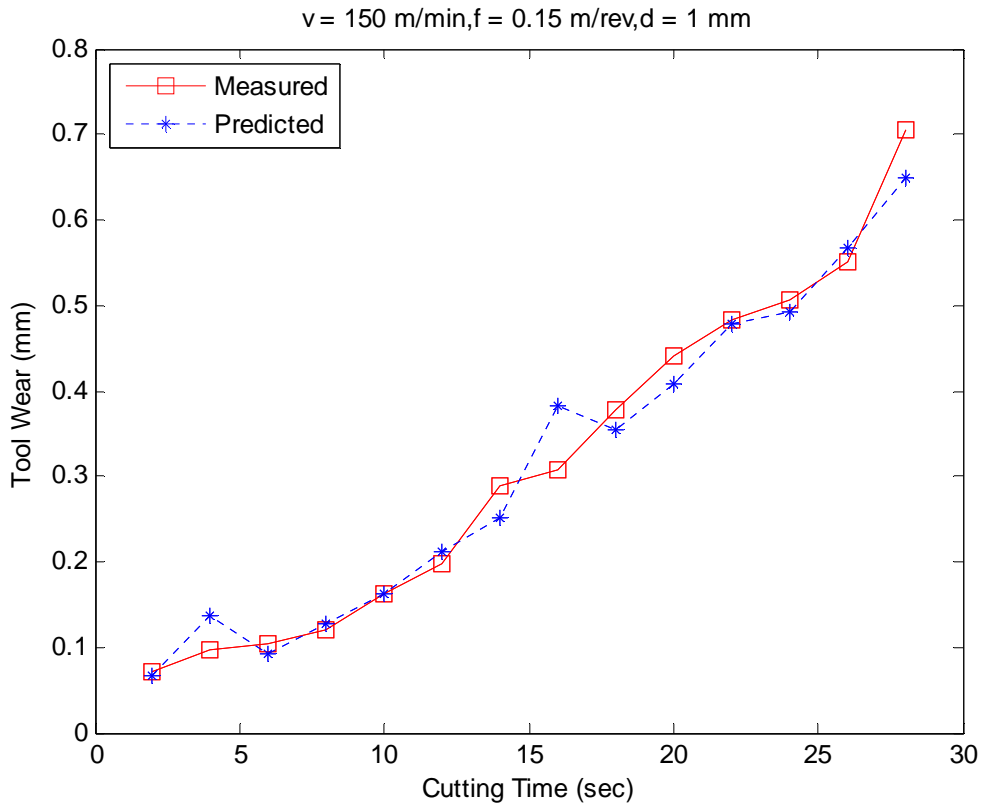

Figure 22: Measured and predicted tool wear through LOONN using S6 set

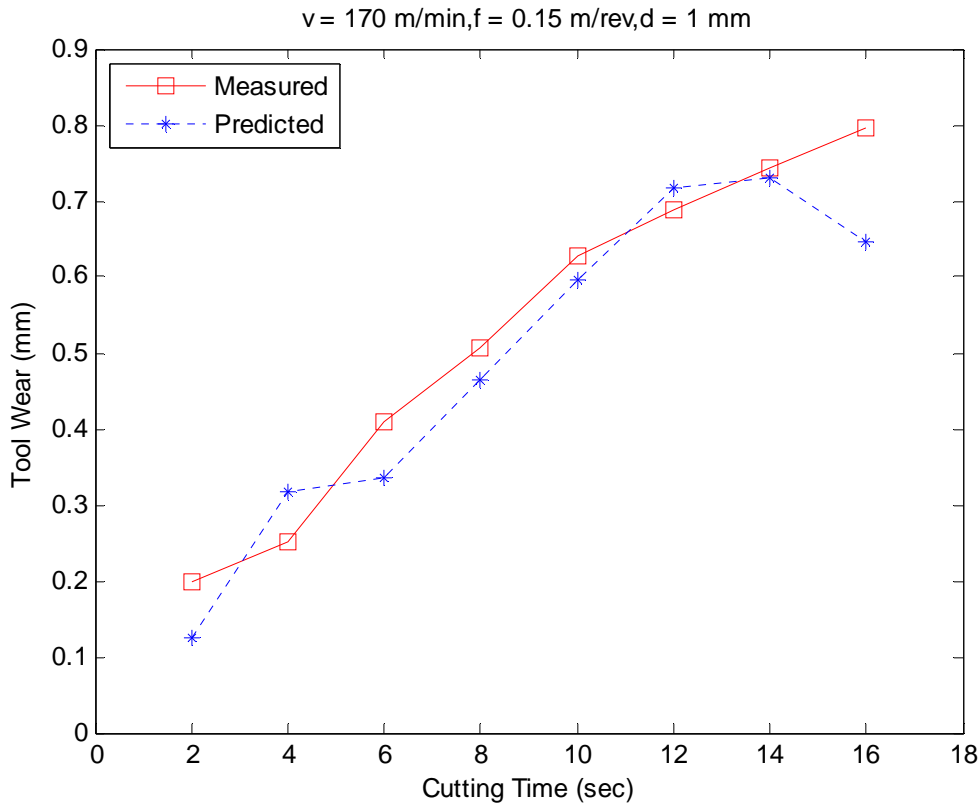

Figure 23: Measured and predicted tool wear through LOONN using S2 set

5.2.2 Results from polynomial classifier model

When developing new techniques to solve a given problem, there is always a chance that those techniques may fail or perform slightly not as good as other existing techniques. This section will determine whether the polynomial classifier model may be applied in tool condition monitoring system to detect tool wear. To achieve this it is necessary to re-run the same simulations used in the previous section.

Experiments performed for neural network are individually selected to be repeated using the new decision making model. The same methods applied in the previous section to train neural network are used here to compare the two models. In addition, the same feature sets are used as inputs for polynomial classifier.

Tables 9-11, present the result obtained using the polynomial classifier for the same machining parameters used in the previous section.

Table 9: PC trial 1 (v = 130 m/min, f = 0.15 mm/rev)

Feature set	Training time (s)	Prediction Accuracy	Classification Accuracy
S1	-	77.58 %	100 %
S2	1.490337	77.60 %	100 %
S3	0.768242	76.47 %	100 %
S4	-	85.28 %	100 %
S5	0.472064	73.07 %	100 %
S6	0.259504	77.26 %	100 %

Table 10: PC trial 2 (v = 170 m/min, f = 0.2 mm/rev)

Feature set	Training time (s)	Prediction Accuracy	Classification Accuracy
S1	-	90.44 %	100 %
S2	1.490337	90.41 %	100 %
S3	0.768242	90.67 %	100 %
S4	-	89.98 %	100 %
S5	0.472064	91.41 %	100 %
S6	0.259504	90.62 %	100 %

Table 11: PC trial 3 (v = 190 m/min, f = 0.15 mm/rev)

Feature set	Training time (s)	Prediction Accuracy	Classification Accuracy
S1	-	96.82 %	100 %
S2	1.490337	96.83 %	100 %
S3	0.768242	95.34 %	100 %
S4	-	95.08 %	100 %
S5	0.472064	95.24 %	100 %
S6	0.259504	95.29 %	100 %

In tables 9-11, the first order model is used. All the sets give almost the same performance accuracy, i.e. redundant values do not affect the polynomial classifier adversely in terms of performance. The computational decision making time, in all experiments is dramatically low, less than two seconds. It should be point out that the reduced features sets in cutting force and AE requires 70% less computational time

comparing to the full features sets. In terms of overall classification performance, the polynomial classifier shows a great ability at rate of 100% in identify worn out tools. Flank wear in the fresh tool state is overestimated sometimes by approximately almost 0.2mm.

The following figures presents measured and predicted amount of tool wear through LOOPC, using the above sets. Figure 24 presents the results using S6 set as inputs. A good matching between measured and predicted values is noticed. Cutting speed $v=110\text{ m/min}$, feed rate $f = 0.15\text{ m/rev}$, depth of cut $d = 1\text{ mm}$. Average accuracy is 87.15%. While Figure 25 presents tool wear prediction using S2 set. Cutting speed $v=170\text{ m/min}$, feed rate $f = 0.15\text{ m/rev}$, depth of cut $d = 1\text{ mm}$. Average accuracy is 95.64%. Figure 26 presents tool wear prediction using S1 set. Cutting speed $v=150\text{ m/min}$, feed rate $f = 0.15\text{ m/rev}$, depth of cut $d = 1\text{ mm}$. Average accuracy is 78.01%. Figure 27 presents tool wear prediction using S1 set. Cutting speed $v=170\text{ m/min}$, feed rate $f = 0.15\text{ m/rev}$, depth of cut $d = 1\text{ mm}$. Average accuracy is 85.78%.

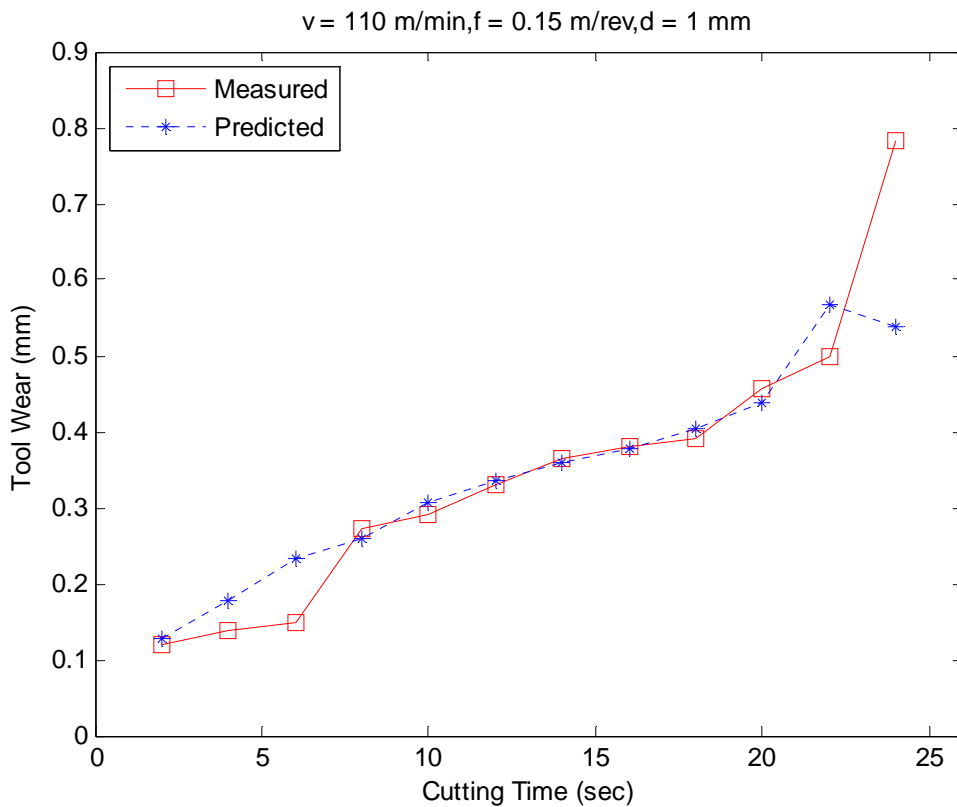

Figure 24: Measured and predicted tool wear through LOOPC using S6 set

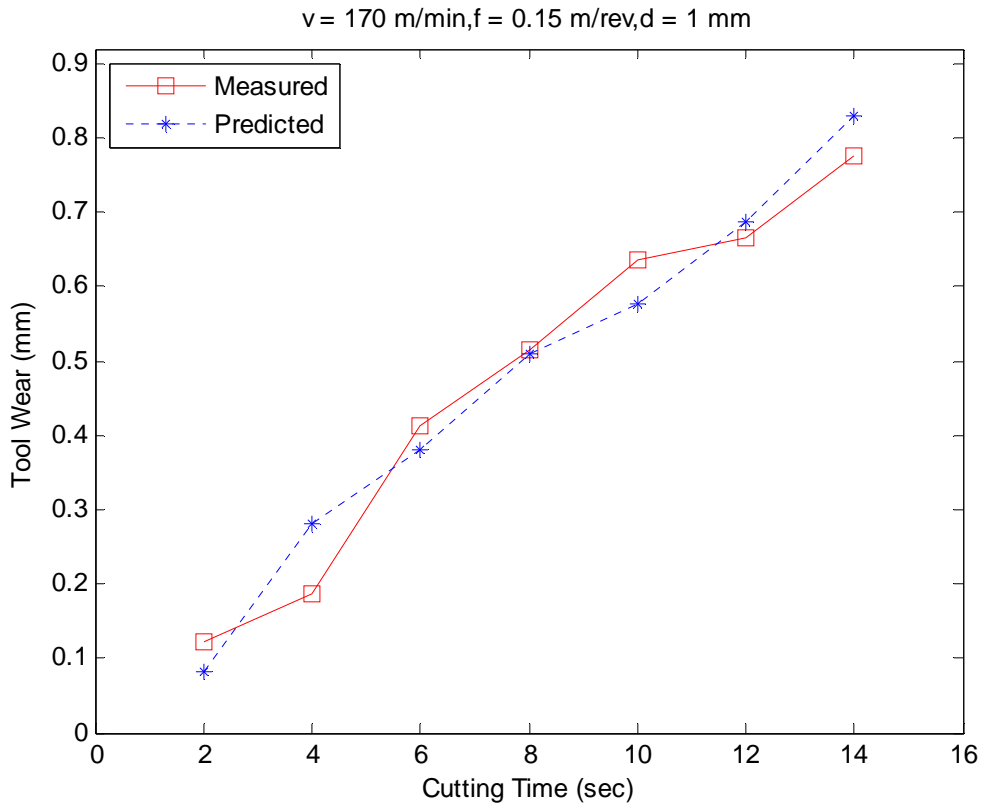

Figure 25: Measured and predicted tool wear through LOOPC using S2 set

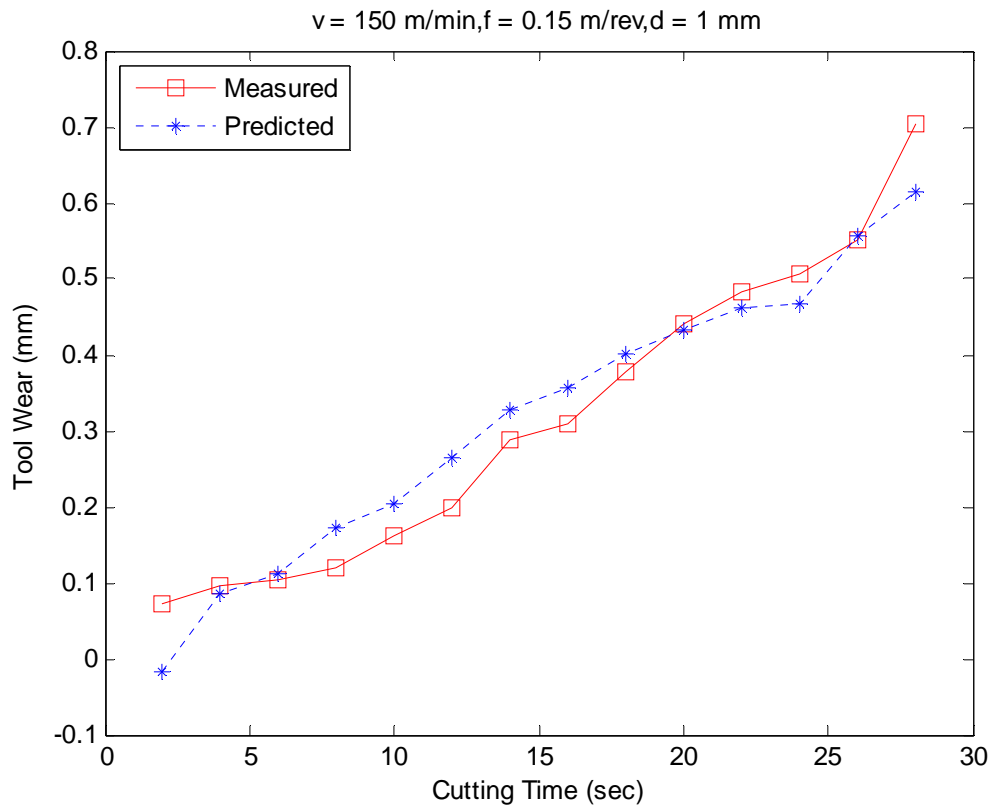

Figure 26: Measured and predicted tool wear through LOOPC using S1 set

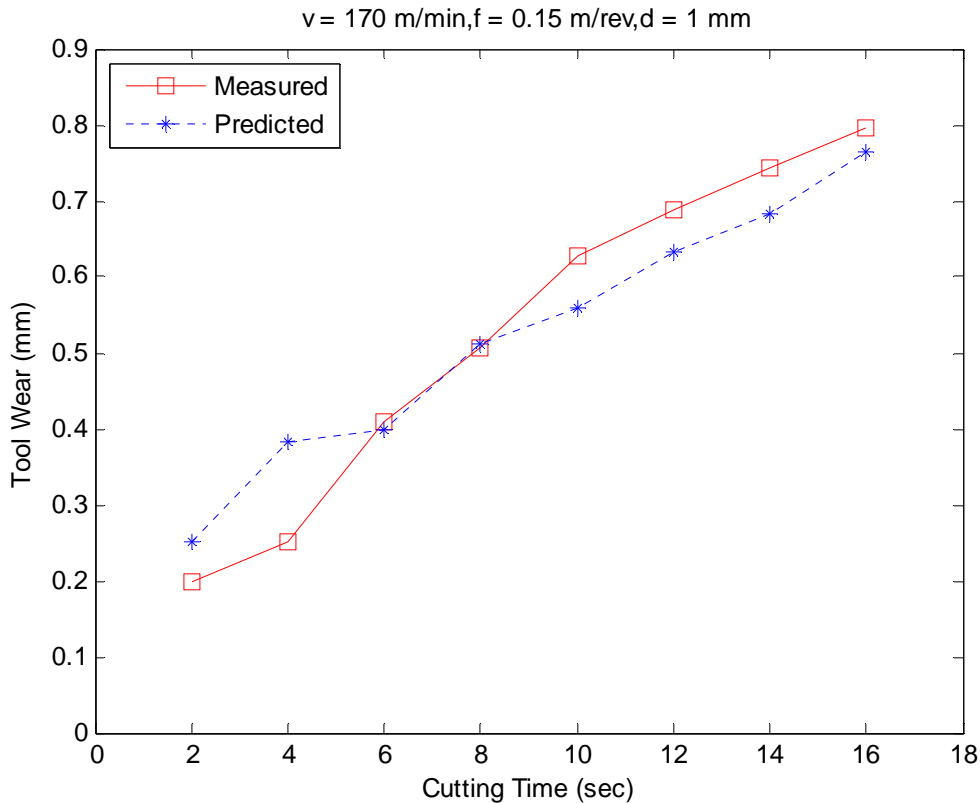

Figure 27: Measured and predicted tool wear through LOOPC using S4 set

5.3 Comparison between neural network and polynomial classifier

Based on the above results, both the BPNN and PC, each acting alone, have a large capability to classify and predict the development of tool wear. The training time has a large effect on the performance of the system. The content of the data used in training the system has a potential effect on the prediction error. BPNN shows better results when more features are used, with the consequence of more training time is required, which results in very slow prediction. On the contrary, more data does not add to PC neither any extra information nor better significant prediction. It should be point out that the slowest training time in PC is less than two seconds, while BPNN need at least two minute for the fastest training time. It has been claimed that tool monitoring system should be independent from the machining parameters [41]. However, it has been observed that this not the case. This matches the results in [14,19]. Both approaches have shown that prediction accuracy is better by adding machining parameters as input features.

5.4 Summary

In this chapter, cutting force and acoustic emission signals acquired in some of used cutting ranges are presented and analyzed. It has been demonstrated that PCA is able to detect and eliminate the majority of outliers. This improves monitoring system performance. Results from neural network and polynomial classifier analyzed. The capability, accuracy, and time efficiency of both classifiers are compared.

CHAPTER 6: CONCLUSION AND RECOMMENDATION FOR FUTURE WORK

6.1 Conclusion

In this thesis the use of intelligent multi sensor in process condition monitoring is studied. The presented methodology involves collecting cutting force and acoustic emission signals while machining mild steel workpiece. The relationship between the acquired signals and the machining parameters, under different tool wear states with different cutting condition using experimental design, is investigated. Two main approaches are considered. The first is the conventional multilayer perceptron back propagation neural network. The second approach is the major novel contribution of this thesis, using polynomial classifier in tool condition monitoring.

Statistical features are extracted from the raw signals which contain an enormous amount of information. In order to overcome the difficulties associated with having too many features acquired from multiple sensory signals, PCA technique has demonstrated effectiveness in features dimensionality reduction. Those features have been interpreted by the two intelligent approaches.

Back propagation neural network and polynomial classifier can predict and classify different tool wear states based on the sensory information. The effectiveness of both proposed decisions making models have been demonstrated in experimental trials. The experimental test results indicate that the proposed methodology results in a good agreement between the predicted and measured tool wear. The prediction accuracy between the two approaches is interchangeable. Comparing to neural network, polynomial classifier shows a significant improvement in the training time. Polynomial classifier requires maximum of two seconds for decision-making. Finally, it has been proved that the sensory signal acquired from low cost sensor and easy to mount, i.e. AE sensor comparing to dynamometer that is expensive and bulky, correlate very well with the tool wear. Further analysis is worthwhile in order to build intelligent monitoring system for turning using the proposed approaches.

6.2 Recommendation for future work

Although a lot of work has been presented in this field, still the improvement for a robust, reliable, and universal intelligent monitoring system is unlimited. The improvement involves hardware and software. The above results are quite encouraging, however there are many avenues for further improvement and research for future extension by

- Using different type of inserts, coated (with different type of coating) and uncoated and covering a wider range of cutting conditions
- Adding different types of sensors, and the so-called dual-mode sensors that permit a simultaneous measurement of two different types of signals [2]
- Using industrial experiments employing same or different cutting conditions ranging from normal to aggressive
- Studying the effect of tool geometry of the tool wear propagation
- Applying new techniques for feature extractions in the frequency domain and the time-frequency domain
- Improving the already used intelligent decision making techniques and trying unsupervised neural networks, such as ART2

REFERENCES

- [1] Groover, M. Fundamentals of modern manufacturing. pp.534-537, John Wiley and Sons, 2nd ed, 2004.
- [2] Schmenk, M. J. Acoustic emission and the mechanics metalcutting. American Society of Mechanical Engineers, Production Engineering Division (Publication) PED, vol. 14, pp. 95-106, 1984.
- [3] Dutta, R.K. Paul, S. Chattopadhyay, A.B. Applicability of the modified back-propagation algorithm in tool condition monitoring for faster convergence. Journal of Materials Processing Technology, v 98, n 3, pp. 299-309, Feb. 2000.
- [4] Kim, K. B. Yoon, D. J. Jeong, J. C. Lee, S. S. Determining the stress intensity factor of a material with an artificial neural network from acoustic emission measurements. NDT and E International, v 37, n 6, pp. 423-429, Sep. 2004.
- [5] Jemielniak, K. Kwiatkowski, L. Wrzosek, P. Diagnosis of tool wear based on cutting forces and acoustic emission measures as inputs to a neural network. Journal of Intelligent Manufacturing, v 9, n 5, pp. 447-455, Oct. 1998.
- [6] Samanta, B. Al-Balushi, K.R. Al-Araimi, S.A Artificial neural networks and support vector machines with genetic algorithm for bearing fault detection, Engineering Application of Artificial Intelligence, v 16, Pp. 657-665, October/December 2003.
- [7] Ghosh, N. Ravi, Y.B. Patra, A. Mukhopadhyay, S. Paul, S. Mohanty, A.R. Chattopadhyay, A.B. Estimation of tool wear during CNC milling using neural network-based sensor fusion. Mechanical system and signal processing. 2005
- [8] Du, R. Elbestawi, M.A. Wu, S.M. Automated monitoring of manufacturing processes, part 2: applications. Journal of Engineering for Industry, Transactions of the ASME, v 117, n 2, pp. 133-141, May. 1995.
- [9] Hong, G.S. Rahman, M. Zhou, Q. Using neural network for tool condition monitoring based on wavelet decomposition. International Journal of Machine Tools & Manufacture, v 36, n 5, pp. 551-566, May. 1996.
- [10] Kuo, R.J Multi-sensor integration for on-line tool wear estimation through artificial neural networks and fuzzy neural network, v 13, Pp. 249-261, Jun 2000.

- [11] Balazinski, M. Czogala, E. Jemielniak, K. Leski, J. Tool condition monitoring using artificial intelligence methods. *Engineering Applications of Artificial Intelligence*, v 15, n 1, pp. 73-80, Feb. 2002.
- [12] Dimla, D.E. Sr. Lister, P.M. On-line metal cutting tool condition monitoring. II: tool-state classification using multi layer perceptron neural networks *International Journal of Machine Tools and Manufacture*, v 40, n 5, pp.769-781, Jan. 2000
- [13] Wong, S.V. Hamouda, A.M.S. Machinability data representation with artificial neural network. *Journal of Materials Processing Technology*, v 138, n 1-3, pp. 538-544, July. 2003
- [14] Silva, R.G. Wilcox, S.J. Reuben, R.L Development of a system for monitoring tool wear using artificial intelligence techniques, *ASME International Mechanical Engineering Congress and Exposition, Proceedings*, v 2, pp. 1003-1010, Nov. 2001.
- [15] Niu, Y.M. Wong, Y.S. Hong, G.S. Intelligent sensor system approach for reliable tool flank wear recognition. *International Journal of Advanced Manufacturing Technology*, v 14, n 2, pp 77-84, 1998.
- [16] Haili, W. Hua, S. Dejin, H. On-line tool breakage monitoring in turning. *Journal of Materials Processing Technology*, v 139, n 1-3 SPEC, pp. 237-242, Aug 20, 2003,
- [17] Sun, J. Hong, G.S. Wong, Y.S. Rahman, M. Wang, Z.G. Effective training data selection in tool condition monitoring system, *International Journal of Machine Tools and Manufacture*, v 46, n 2, pp. 218-224, Feb. 2006.
- [18] Shi, D. Gindy, N. Tool wear predictive model based on least squares support vector machines. *Mechanical Systems and Signal Processing*, vol. 21, no. 4, pp. 1799-1814, May. 2007.
- [19] Sun, J. Hong, G.S. Rahman, M. Wong, Y.S. Identification of feature set for effective tool condition monitoring by acoustic emission sensing. *International Journal of Production Research*, vol. 42, no. 5, pp. 901-918, Mar. 2004.
- [20] Yao, Y. Li, X. Yuan, Z. Tool wear detection with fuzzy classification and wavelet fuzzy neural network. *International Journal of Machine Tools and Manufacture*, vol. 39, no. 10, pp. 1525-1538, Jun. 1999.

- [21] Li, X. Djordjevich, A. Venuvinod, P. Current sensor based feed cutting force intelligent estimation and tool wear condition monitoring, *IEEE Transactions on Industrial Electronics*, vol. 47, no. 3, pp 697-702, Jun. 2000.
- [22] Santanu, D. Chattopadhyay, A.B. Application of the analytic hierarchy process for estimating the state of tool wear, *International journal of machine tools and manufacture*, vol. 43, no. 1, pp. 1-6, Jan. 2003.
- [23] Jiaa, Ch.L. Dornfeld, D.A. Self-organizing approach to the prediction and detection of tool wear *ISA Transactions*, vol. 37, no. 4, pp. 239-255,1998.
- [24] Astakhov, V. , The assessment of cutting tool wear, *International Journal of Machine Tools and Manufacture*, vol. 44, no. 6, pp. 637-647, May 2004.
- [25] Li, X. A brief review: acoustic emission method for tool wear monitoring during turning. *International Journal of Machine Tools and Manufacture*, vol. 42, no. 2, pp. 157-165, Jan. 2002.
- [26] Arul, S. Vijayaraghavan, L. Malhotra, S.K. Online monitoring of acoustic emission for quality control in drilling of polymeric composites. *Journal of Materials Processing Technology*, vol. 185, no. 1-3, pp. 184-190, Apr 30, 2007, ICAMT 2004 (Malaysia) and CCAMT 2004 (India) Special Issue.
- [27] Lu, M, Kannatey-Asibu Jr., E. Analysis of sound signal generation due to flank wear in turning. *Journal of Manufacturing Science and Engineering, Transactions of the ASME*, vol. 124, no. 4, pp. 799-808, Nov. 2002.
- [28] Gao, R.X. Neural networks for machine condition monitoring and fault diagnosis *Neural networks for instrumentation, Measurement and related industrial application*. IOS Press, 2003.
- [29] Li, H.Z., Zeng, H. Chen,X.Q. An experimental study of tool wear and cutting force variation in the end milling of Inconel 718 with coated carbide inserts, *Journal of materials processing technology*, vol. 180, no. 1-3, pp 296-304, Dec. 2006.
- [30] Sikdar, S.K. Chen, M. Relationship between tool flank wear and component forces in single point turning, *Journal of materials processing technology*, vol. 128, no. 1-3, pp. 210-215, Oct 2002.

- [31] Huang, S.N. Tan, K.K. Wong, Y.S. Silva, C.W. de Goh, H.L. Tan, W.W. Tool wear detection and fault diagnosis based on cutting force monitoring, *International Journal of Machine Tools and Manufacture*, v 47, pp. 444-451, Mar. 2007.
- [32] Oraby, S.E. Hayhurst, D.R. Tool life determination based on the measurement of wear and tool force ratio variation, *International Journal of Machine Tools and Manufacture*, vol. 44, no. 12-13, pp. 1261-1269, Oct 2004.
- [33] Choudhury, S.K. Kishore, K.K. Tool wear measurement in turning using force ratio, *International Journal of Machine Tools and Manufacture*, vol. 40, no. 6, pp. 899-909, Feb 2000.
- [34] Choudhury, S.K. Rath, S. In process tool wear estimation in milling using cutting force model, *Journal of Materials Processing Technology*, vol. 99, no. 1, pp 113-119, Mar 2000.
- [35] Engineering fundamentals. www.efunda.com
- [36] MATLAB. www.mathworks.com
- [37] Daynoware. www.kistler.com
- [38] Jemielniak, K. Some aspects of acoustic emission signal pre-processing. *Journal of Materials Processing Technology*, vol. 109, no. 3, pp. 242-247, Feb. 2001.
- [39] Ravindra, H.V. Srinivasa, Y.G. Krishnamurthy, R. Acoustic emission for tool condition monitoring in metal cutting, *Wear*, vol. 212, no. 1, pp. 78-84, Nov 30, 1997.
- [40] Roget, J. Souquet, P. Gsib, N. Application of acoustic emission to the automatic monitoring of tool condition during machining. *Materials Evaluation*, vol. 46, no. 2, pp. 225-229, Feb. 1988,
- [41] Sick, B. On-line and indirect tool wear monitoring in turning with artificial neural networks a review of more than a decade of research. *Mechanical Systems and Signal Processing*, vol. 16, no. 4, pp. 487 – 546, 2002.
- [42] Lee, J.H. Lee, S.J. One-step-ahead prediction of flank wear using cutting force. *International Journal of Machine Tools and Manufacture*, vol. 39, no. 11, pp. 1747-1760, Nov, 1999.
- [43] Liu, Q. Altintas, Y. On-line monitoring of flank wear in turning with multilayered feed-forward neural network. *International Journal of Machine Tools and Manufacture*, vol. 39, no. 12, pp. 1945-1959, Sep. 1999.

- [44] Yeo, S.H. Khoo, L.P. Neo, S.S. Tool condition monitoring using reflectance of chip surface and neural network. *Journal of Intelligent Manufacturing*, vol. 11, no. 6, pp. 507-514, Dec, 2000.
- [45] Xiaoli, L. Xin, Y. Multi-scale statistical process monitoring in machining. *IEEE Transactions on Industrial Electronics*, vol. 52, no. 3, pp. 924-927, June. 2005.
- [46] Jemielniak, K. Otman, O. Tool failure detection based on analysis of acoustic emission signals. *Journal of Materials Processing Technology*, vol. 76, no. 1-3, pp. 192-197Apr, 1998.
- [47] Kannatey-Asibu, E. Jr. Dornfeld, D. A. Study of tool wear using statistical analysis of metal-cutting acoustic emission. *Wear*, vol. 76, no. 2, pp. 247-261Feb 15, 1982.
- [48] Ravindra, H.V. Srinivasa, Y.G. Krishnamurthy, R. Acoustic emission for tool condition monitoring in metal cutting. *Wear*, vol. 212, no. 1, pp. 78-84, Nov 30, 1997.
- [49] Ko, T. J. Cho, D. W. Cutting state monitoring in milling by a neural network. *International Journal of Machine Tools & Manufacture*, vol. 34, no. 5, p 659-676, Jul, 1994.
- [50] Kwak, Jae-Seob Ha, Man-Kyung Neural network approach for diagnosis of grinding operation by acoustic emission and power signals. *Journal of Materials Processing Technology*, vol. 147, no. 1, pp. 65-71, Mar 30, 2004.
- [51] Kwak, Jae-Seob Song, Ji-Bok Trouble diagnosis of the grinding process by using acoustic emission signals. *International Journal of Machine Tools and Manufacture*, vol. 41, no. 6, pp. 899-913, May, 2001.
- [52] Young Jun Choi, Min Soo Park, Chong Nam Chu. Prediction of drill failure using features extraction in time and frequency domains of feed motor current. *International Journal of Machine Tools and Manufacture* .vol. 48, no. 1, pp. 29-39, Jan. 2008.
- [53] Wu, Ya Du, R.Feature extraction and assessment using wavelet packets for monitoring of machining processes. *Mechanical Systems & Signal Processing*, vol 10, no. 1, pp. 29-53, Jan. 1996.
- [54] Scheffer, C. Heyns, P.S.Wear monitoring in turning operations using vibration and strain measurement. *Mechanical Systems and Signal Processing*, vol. 15, no. 6, pp. 1185-1202, Nov. 2001.

- [55] Haykin, S. Neural networks a comprehensive foundation, pp. 392-440 Hamilton, Ontario, Canada. Prentice Hall. 2nd ed. 1999
- [56] Sun, R. Tsung, F. Qu, L. Evolving kernel principal component analysis for fault diagnosis. Computers and Industrial Engineering, vol. 53, no. 2, p 361-371, Sep. 2007, Selected Papers from The 27th. International Conference on Computers and Industrial Engineering - Part 2.
- [57] Kim, K. I. Jung, K. Kim, H. J. Face recognition using kernel principal component analysis. IEEE Signal Processing Letters, vol. 9, no. 2, pp. 40-42, Feb. 2002.
- [58] Dong K. K. Nam S. K. Rapid speaker adaptation using probabilistic principal component analysis. IEEE Signal Processing Letters, vol. 8, no. 6, pp. 180-183, June, 2001.
- [59] Twining, C. J. Taylor, C. J. The use of kernel principal component analysis to model data distributions. Pattern Recognition, vol. 36, no. 1, pp. 217-227, Jan. 2003.
- [60] Jolliffe, I. T. Principal Component Analysis. Secaucus, NJ, USA: Springer-Verlag New York, Incorporated, 2002. p 1.
- [61] Sick, B. Tool wear monitoring in turning: a neural network application. Measurement and Control, vol. 34, no. 7, pp. 207-211+222, Sep. 2001.
- [62] Sick, B. On-line and indirect tool wear monitoring in turning with artificial neural networks: a review of more than a decade of research. Mechanical Systems and Signal Processing, vol. 16, no. 4, pp. 487-546, July. 2002.
- [63] Wan, V. Speaker verification using support vector machines. PhD thesis, University of Sheffield, June 2003.

VITA

Firas F. Hammad was born in Dubai, UAE, on June 13, 1983. He attended his primary, elementary, and high school in Al-Ain. In August 2001, he entered the American University of Sharjah and in June 2005 received the degree of Bachelor of Science in Mechanical Engineering. He joined, in August 2005, the master program in Mechatronics at the American University of Sharjah. He was awarded the Master of Science degree in Mechatronics in December 2007. Right now, he is working in the Consolidated Contractors International Company.